

සියලු ම හිමිකම් ඇවිරිණි/முழுப் பதிப்புரிமையுடையது/All Rights Reserved

අධ්‍යාපන, උසස් අධ්‍යාපන සහ වෘත්තීය අධ්‍යාපන අමාත්‍යාංශය
 කல்வி, உயர் கல்வி மற்றும் தொழிற கல்வி அமைச்சு
 Ministry of Education, Higher Education and Vocational Education

අ.පො.ස. (උ.පෙළ) උපකාරක සම්මන්ත්‍රණය - 2025

සංයුක්ත ගණිතය I
 இணைந்த கணிதம் I
 Combined Mathematics I



පැය තුනයි
 மூன்று மணித்தியாலம்
 Three hours

අමතර කියවීමේ කාලය - මිනිත්තු 10 යි
 மேலதிக வாசிப்பு நேரம் - 10 நிமிடங்கள்
 Additional Reading Time - 10 minutes

අමතර කියවීමේ කාලය පුද්ගලිකව පමණක් භාවිතයට පමණක් පිළිබඳව ලිවීමේදී ප්‍රමුඛවත්වය දෙන පුද්ගලික සංවිධානය කර ගැනීමට යොදාගන්න.

විභාග අංකය

--	--	--	--	--	--	--	--

උපදෙස්:

- * මෙම පුද්ගලික පත්‍රය කොටස් දෙකකින් සමන්විත වේ;
A කොටස (ප්‍රශ්න 1 - 10) සහ **B කොටස** (ප්‍රශ්න 11 - 17).
- * **A කොටස:**
 සියලුම ප්‍රශ්නවලට පිළිතුරු සපයන්න. එක් එක් ප්‍රශ්නය සඳහා ඔබේ පිළිතුරු, සපයා ඇති ඉඩේහි ලියන්න. වැඩිපුර ඉඩ අවශ්‍ය වේ නම්, ඔබට අමතර ලියන කඩදාසි භාවිත කළ හැකි ය.
- * **B කොටස:**
 පුද්ගලික පමණක් පිළිතුරු සපයන්න. ඔබේ පිළිතුරු, සපයා ඇති කඩදාසිවල ලියන්න.
- * නියමිත කාලය අවසන් වූ පසු **A කොටසෙහි** පිළිතුරු පත්‍රය, **B කොටසෙහි** පිළිතුරු පත්‍රයට උඩින් සිටින පරිදි කොටස් දෙක අමුණා විභාග ශාලාධිපතිට භාර දෙන්න.
- * පුද්ගලික පත්‍රයෙහි **B කොටස පමණක්** විභාග ශාලාවෙන් පිටතට ගෙන යාමට ඔබට අවසර ඇත.

පරීක්ෂකවරුන්ගේ ප්‍රයෝජනය සඳහා පමණි.

(10) සංයුක්ත ගණිතය I		
කොටස	ප්‍රශ්න අංකය	ලකුණු
A	1	
	2	
	3	
	4	
	5	
	6	
	7	
	8	
	9	
	10	
B	11	
	12	
	13	
	14	
	15	
	16	
	17	
	එකතුව	

එකතුව

ඉලක්කමෙන්	
අකුරින්	

සංකේත අංක

උත්තර පත්‍ර පරීක්ෂක	
පරීක්ෂා කළේ:	1
	2
අධීක්ෂණය කළේ:	

අ.පො.ස. (උ.පෙළ) උපකාරක සම්මන්ත්‍රණය - 2025

සංයුක්ත ගණිතය I
 இணைந்த கணிதம் I
 Combined Mathematics I



B කොටස

* ප්‍රශ්න පහකට පමණක් පිළිතුරු සපයන්න.

11. (a) $f(x) = x^2 - \lambda x + c^2$ යැයි ගනිමු; මෙහි λ හා c යනු තාත්වික නියත වේ. $f(x)$ හි අවම අගය $\frac{4c^2 - \lambda^2}{4}$ බව පෙන්වන්න.

$y = f(x)$ හි ප්‍රස්තාරය ප්‍රභින්න ලක්ෂ්‍ය දෙකකදී x -අක්ෂය ඡේදනය කරයි නම් $\lambda > 2|c|$ බව අපෝහනය කරන්න.

α හා β යනු $f(x) = 0$ හි මූල යැයි ගනිමු. α හා β දෙකම ධන බව දී ඇත.

$\sqrt{\alpha} + \sqrt{\beta} = \sqrt{\lambda + 2|c|}$ බව පෙන්වන්න.

ඒ නයින්, $\sqrt{\alpha} - \frac{1}{\sqrt{\alpha}}$ හා $\sqrt{\beta} - \frac{1}{\sqrt{\beta}}$ මූල ලෙස ඇති වර්ගජ සමීකරණය

$|c|x^2 - \sqrt{\lambda + 2|c|}(|c| - 1)x + c^2 - \lambda + 1 = 0$ මගින් දෙනු ලබන බව පෙන්වන්න.

$g(x) = |c|x^2 - \sqrt{\lambda + 2|c|}(|c| - 1)x + c^2 - \lambda + 1$ ලෙස ගනිමු.

$y = f(x)$ හා $y = g(x)$ හි ප්‍රස්තාර y -අක්ෂය මත දී හමුවේ නම් $\lambda = 1$ බව පෙන්වන්න.

(b) $f(x)$ යනු මාත්‍රය 3 වූ බහුපදයක් යැයි ගනිමු. $f(x)$ යන්න $x^2 - 3x + 2$, $x^2 - 5x + 6$ හා $x^2 - 4x + 3$ මගින් වෙන වෙනම බෙදූ විට ශේෂය $11x - 6$ වේ. $f(0) = 0$ නම් $f(x)$ සොයන්න. තව දුරටත් $y = f(x)$ හි ප්‍රස්තාරයේ අනුක්‍රමණය සඳහා ගත හැකි උපරිම අගය 12 බව අපෝහනය කරන්න.

12. (a) P_1, P_2, P_3 කුලක තුන පිළිවෙළින් $P_1 = \{\alpha, \beta, \gamma\}$, $P_2 = \{A, B, C\}$, සහ $P_3 = \{1, 3, 5\}$ ලෙස සලකමු.

$P_1 \cup P_2 \cup P_3$ කුලකයෙන් අවයව භාවිතයෙන් සංකේත පහකින් සමන්විත මූරපදයක් සෑදීමට අවශ්‍යව ඇත.

(I) ඉහත අවයව භාවිතයෙන් සැකසිය හැකි එවැනි වෙනස් මූරපද සංඛ්‍යාව

I. තෝරා ගැනීම් පිළිබඳ කිසිදු සීමා කිරීමක් නැති විට

II. හරියටම සංඛ්‍යාංක දෙකක් ම පමණක් ඇතුළත් විය යුතු විට සොයන්න.

(II) P_1 න් හරියටම එක් අවයවයක් සහ P_2 න් හරියටම අවයව දෙකක් ඇතුළත් වන පරිදි සහ P_3 න්

තෝරා ගන්නා අවයව සඳහා පමණක් පුනරාවර්තනය කල හැකි විට සැකසිය හැකි වෙනස් මූරපද සංඛ්‍යාව සොයන්න.

(b) $r \in \mathbb{Z}^+$ සඳහා $U_r = \frac{9(3r+4)}{(3r-1)(3r+2)(3r+5)}$ හා $f(r) = \frac{A}{(3r-1)} + \frac{B}{(3r+2)}$ යැයි ගනිමු,

A හා B තාක්ත්වික නියත වේ.

$r \in \mathbb{Z}^+$ සඳහා $U_r = f(r) - f(r+1)$ වන පරිදි $A = \frac{5}{2}$ හා $B = \frac{1}{2}$ බව පෙන්වන්න.

ඒ නයින්, $n \in \mathbb{Z}^+$ සඳහා $\sum_{r=1}^n U_r = \frac{27}{20} - \frac{5}{2(3n+2)} - \frac{1}{2(3n+5)}$ බව පෙන්වන්න.

$\sum_{r=1}^{\infty} U_r$ අපරිමිත ශ්‍රේණිය අභිසාරී බව අපෝහනය කර එහි ඵලය සොයන්න.

ඒ නයින්, $\sum_{r=1}^{\infty} (U_r + kU_{r+2}) \leq 1$ වන පරිදි k සඳහා ගත හැකි විශාලතම තාක්ත්වික නියතයෙහි අගය සොයන්න.

13. (a) (i) $(PQ)^T = Q^T P^T$ වන පරිදි වූ P, Q න්‍යාස දෙකක් සහ සන්‍ය එකම වූ A, B සමවතුරු න්‍යාස දෙකක් සලකමු. A යනු සමමිතික න්‍යාසයක් නම් $B^T A B$ සමමිතික බවත් A කුටික සමමිතික නම් $B^T A B$ කුටික සමමිතික බවත් සාධනය කරන්න.

(ii) $A(x)$ න්‍යාසය, $A(x) = (1 - x^2)^{-\frac{1}{2}} \begin{pmatrix} 1 & x \\ x & 1 \end{pmatrix}$ ලෙස ගනිමු; මෙහි $x \in \mathbb{R}, |x| < 1$.

$A(x)A(y) = A(z)$ බව දී ඇත. z යන්න x හා y ඇසුරින් නිර්ණය කරන්න. ඒ නයින්, $A(x)$ හි ප්‍රතිලෝම න්‍යාසය සොයන්න.

(b) ආගන්ධ සටහනක P ලක්ෂ්‍යය z සංකීර්ණ සංඛ්‍යාව නිරූපනය කරයි. මෙහි $z = r(\cos \theta + i \sin \theta)$; $r > 0, -\pi < \theta \leq \pi$ වේ. z^2 නිරූපනය කරන Q ලක්ෂ්‍යය දැක්වීමට ජ්‍යාමිතික නිර්මාණයක් ඉදිරිපත් කරන්න.

$|1 + z| = 1$ මගින් නිරූපනය කරන z සංකීර්ණ සංඛ්‍යාවල පථය දළ සටහනක් මගින් දක්වන්න. ඒ නයින්, $|1 + z| = 1$ සහ $|z^2 + 1| = 1$ වන පරිදි z සොයන්න.

(c) $\omega = \cos \frac{2\pi}{5} + i \sin \frac{2\pi}{5}$ යැයි ගනිමු. ද මුවාවර් ප්‍රමේයය භාවිතයෙන් ω^5 සොයන්න.

$1 + \omega + \omega^2 + \omega^3 + \omega^4 = 0$ බව සාධනය කරන්න.

ඒ නයින්, $\cos \frac{\pi}{5} - \cos \frac{2\pi}{5}$ හි අගය සොයන්න.

14. (a) $x \in \mathbb{R} - \{-4\}$ සඳහා $f(x) = \frac{x(x-4)}{(x+4)^2}$ යැයි ගනිමු.

$x \neq -4$ සඳහා $f(x)$ හි ප්‍රථම ව්‍යුත්පන්නය වන $f'(x)$ යන්න, $f'(x) = \frac{4(3x-4)}{(x+4)^3}$ මගින් දෙනු ලබන බව පෙන්වන්න.

ඒ නයින්, $f(x)$ අඩුවන ප්‍රාන්තරය හා වැඩිවන ප්‍රාන්තර සොයන්න.

ස්පර්ශෝත්මය, හැරුම් ලක්ෂ්‍ය, x -අක්ෂය ඡේදනය කරන ලක්ෂ්‍යය, y -අක්ෂය ඡේදනය කරන ලක්ෂ්‍යය දක්වමින් $y = f(x)$ හි ප්‍රස්තාරයේ දළ සටහනක් අඳින්න.

$x \neq -4$ සඳහා $f''(x) = \frac{-24(x-4)}{(x+4)^4}$ බව දී ඇත.

$y = f(x)$ වක්‍රයේ නතිවර්තන ලක්ෂ්‍යයේ ඛණ්ඩාංකය $(4,0)$ බව පෙන්වන්න.

$x < -8$ සඳහා $y = \frac{x(x+4)}{(x+8)^2}$ හි ප්‍රස්තාරය අපෝභනය කරන්න.

(b) යාබද රූපයෙන් පෙන්වන්නේ OAB හා DCE තල මුහුණත් දෙකකින් සමන්විත චීස් කැබැල්ලකි. ඉහත එක් එක් මුහුණත අරය r cm වූ වෘත්තයක කේන්ද්‍රයේ රේඩියන α කෝණයක් ආපාතනය කරන කේන්ද්‍රික ඛණ්ඩ වේ. මෙහි $0 < \alpha < \frac{\pi}{2}$ වේ. රූපයේ දැක්වෙන පරිදි h cm ඝනකම සහිත ඝන වස්තුවක පෙනුම ලබාදෙමින් OD , BE හා AC දාර තුනම ඉහත මුහුණත් දෙකට ලම්බ ව පිහිටයි. චීස් කැබැල්ලේ පරිමාව 9 cm^3 ලෙස දී ඇත. චීස් කැබැල්ලේ පෘෂ්ඨ වර්ගඵලය S යන්න, $S = r^2\alpha + \frac{18(2+\alpha)}{r\alpha}$ මගින් දෙනු ලබන බව පෙන්වන්න.

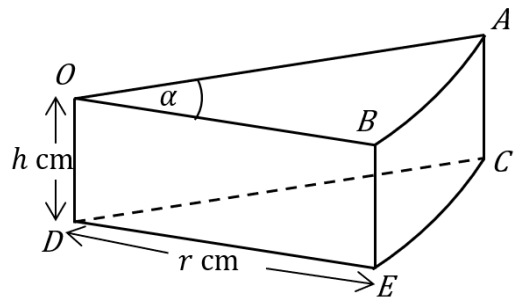

ඒ නයින්, $\alpha = 1$ රේඩියන සඳහා S අවම වන පරිදි r හි අගය සොයන්න.

15. (a) සියළු $x \in \mathbb{R}$ සඳහා $x^2 + 2 \equiv A(x^2 - 2x + 4) + (Bx + C)(x + 2)$ වන පරිදි A, B හා C නියත වල අගයන් සොයන්න.

ඒ නයින්, $\int \frac{x^2 + 2}{x^3 + 8} dx$ සොයන්න.

(b) සුදුසු ආදේශයක් භාවිතයෙන්, a හා b නියත වන පරිදි $\int_a^b f(x) dx = \int_a^b f(a+b-x) dx$ බව සාධනය කරන්න.

$$I = \int_{\frac{\pi}{3}}^{\frac{2\pi}{3}} \frac{\sin x}{\cos x - \sin x} dx \text{ යැයි ගනිමු. } I = \int_{\frac{\pi}{3}}^{\frac{2\pi}{3}} \frac{-\sin x}{\cos x + \sin x} dx \text{ බව පෙන්වන්න.}$$

$$\int_{\frac{\pi}{3}}^{\frac{2\pi}{3}} \tan 2x dx = 0 \text{ බව අපෝභනය කරන්න.}$$

$\sin x = \lambda (\cos x - \sin x) - \mu (\cos x + \sin x)$ වන පරිදි λ හා μ තාත්ත්වික නියත වල අගයන් සොයා $I = \ln\left(\frac{\sqrt{3}-1}{\sqrt{2}}\right) - \frac{\pi}{6}$ බව පෙන්වන්න.

(c) $y = \sec^2 x - \tan x$ යැයි ගනිමු. $\frac{dy}{dx}$ සොයන්න.

ඒ නමින්, $\int_0^{\frac{\pi}{3}} \sec^2 x (\tan x - 1) dx$ හි අගය සොයන්න.

16. $A \equiv (1,2)$ ලක්ෂ්‍යය $l \equiv ax + by - 3 = 0$ සරල රේඛාව මත ඇතැයි සලකමු. මෙහි $a, b \in \mathbb{R}$ වේ. තවද l රේඛාවේ පරාමිතික සමීකරණ $x = 2t + 1, y = t + 2$ යැයි දී ඇත. මෙහි t යනු පරාමිතියකි. a හා b හි අගයන් සොයන්න.

$S \equiv x^2 + y^2 - 4x - 5y + 9 = 0$ වෘත්තය l රේඛාව මගින් A හා B හිදී ජේදනය වේ යැයි ගනිමු. B ලක්ෂ්‍යයේ ඛණ්ඩාංක සොයන්න.

$S = 0$ වෘත්තයෙහි කේන්ද්‍රය l රේඛාව මත පිහිටන බව පෙන්වා කේන්ද්‍රය B හා අරය $\frac{\sqrt{10}}{2}$ වන S_1 වෘත්තයට A සිට ඇදී ස්පර්ශක වල සමීකරණ සොයන්න.

ඉහත එක් ස්පර්ශකයක් හා l රේඛාව අතර කෝණය සොයන්න. ඉහත ස්පර්ශක දෙකක් S හා S_1 වෘත්ත වල පොදු ජ්‍යායන් මගින් ආවෘත වන වර්ගඵලය සොයන්න.

17. (a) $\theta \neq \frac{n\pi}{2}$ සහ $n \in \mathbb{Z}$ සඳහා $\cot \theta \equiv \operatorname{cosec} 2\theta + \cot 2\theta$ බව සාධනය කරන්න.

ඒ නමින්, $\cot \frac{\pi}{12} = 2 + \sqrt{3}$ බව පෙන්වන්න. ඒ නමින්, $\operatorname{cosec}^2 \frac{\pi}{12}$ සොයන්න.

$\operatorname{cosec} \frac{\pi}{12} = \sqrt{x} + \sqrt{y}$ වන පරිදි x හා y ධන නිඛිල වල අගයන් නිර්ණය කරන්න.

$\tan \frac{\pi}{24}$ අපෝහනය කරන්න.

(b) සුපුරුදු අංකනයෙන් ඕනෑම ත්‍රිකෝණයක් සඳහා සයින් නීතිය ප්‍රකාශ කර සාධනය කරන්න.

ABC ත්‍රිකෝණයක $BC = 5$ cm, $AC = 4$ cm, සහ $A = \frac{\pi}{2} + B$ වේ. $\tan C = \frac{9}{40}$ බව පෙන්වන්න.

ඒ නමින්, $\sin B$ හා AB දිග සොයන්න. BAC කෝණයේ අභ්‍යන්තර කෝණ සමච්චේදකය හා BC පාදය D හිදී හමුවේ. BD දිග සොයන්න.

(c) $\cos^{-1}(1-x) = 2 \sin^{-1} x$ සමීකරණය විසඳන්න.

12. (a) රූපයේ දැක්වෙන්නේ X සහ Y ඒකාකාර කුඳ්ඳු දෙකක සහ P, Q සහ R අංශු තුනක ස්කන්ධ කේන්ද්‍ර හරහා ගමන් කරන සිරස් හරස්කඩකි. ස්කන්ධය M වන Y කුඳ්ඳු අවල X කුඳ්ඳුයේ රළ තිරස් මුහුණත මත තබා ඇත. α සහ β පිළිවෙලින් X සහ Y හි සුමට ආනත මුහුණත් වල වැඩිතම බෑවුම් වේ. A සහ B යනු පිළිවෙලින් X සහ Y කුඳ්ඳු වලට සවි කර ඇති කුඩා සුමට කප්පි දෙකකි. C යනු BC තිරස් වන පරිදි එකම සිරස් තලයේ පිහිටි අවල කප්පියකි. ස්කන්ධ පිළිවෙලින් m_1 සහ m_2 වූ P සහ Q අංශු දෙකක් B සහ C මතින් ගමන් කරන සැහැල්ලු අවිනන්‍ය තන්තුවක දෙකෙළවරට ඇඳා ඇත. Y ට සවිකර ඇති A කප්පිය මතින් ගමන් කරන තවත් සැහැල්ලු අවිනන්‍ය තන්තුවක් X හි ආනත මුහුණත මත තබා ඇති ස්කන්ධය m_3 වූ R අංශුවකට සම්බන්ධ කර ඇත. X සහ Y අතර සර්ඡණ සංගුණකය μ වේ. තන්තු තදව ඇතිව පද්ධතිය නිශ්චලතාවයෙන් මුදා හරිනු ලැබේ. P අංශුව සම්පූර්ණ වලිතය අතරතුර, Y හි ආනත තලය සමඟ ස්පර්ශව පවතින බව උපකල්පනය කරමින්, අංශුවල සහ කුඳ්ඳුයේ ත්වරණ නිර්ණය කිරීමට ප්‍රමාණවත් සමීකරණ ලියා දක්වන්න.

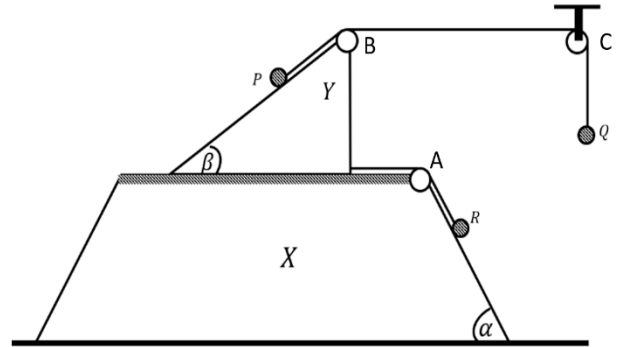

(b) දිග $2a$ වූ සැහැල්ලු අවිනන්‍ය තන්තුවක එක් කෙළවරක් අවල O ලක්ෂ්‍යයකට ද අනෙක් කෙළවර ස්කන්ධය m වූ P_1 අංශුවකට ද ඇඳා ඇත. අංශුව $OP_1 = 2a$ වන පරිදි O හා එකම මට්ටමේ තබා සිරස්ව පහලට $\sqrt{5ag}$ වේගයකින් ප්‍රක්ෂේප කරනු ලැබේ. OP_1 තිරස සමඟ θ ($0 < \theta < \frac{\pi}{2}$) කෝණයක් සාදන විට P_1 අංශුවේ වේගය V ; $V^2 = ag(5 + 4 \sin \theta)$ මගින් දැක්වෙන බව පෙන්වා තන්තුවේ ආතතිය සොයන්න. P_1 අංශුව එහි පහලම ස්ථානය වූ B ට පැමිණි විට O සිට $3a$ පහළින් වූ B නම් ලක්ෂ්‍යයක සිට සිරස්ව ඉහලට $\sqrt{2ag}$ වේගයෙන් ප්‍රක්ෂේපනය කරන ලද ස්කන්ධය m වූ P_2 අංශුවක් සමඟ කෙළින්ම ගැටේ. ගැටුමෙන් පසු P_1, P_2 වලිතයේ දී, P_1 වෘත්තාකාර වලිතය ම පවත්වා ගනු ලබන අතර OD යටි අත් සිරස සමඟ θ කෝණයක් සාදන ලක්ෂ්‍යයේ දී ක්ෂණික නිශ්චලතාවයට පත් වේ. P_2 අංශුව ගුරුත්වය යටතේ වලනය වී D ට සිරස්ව පහළින් පිහිටි E ලක්ෂ්‍යය කරා ළඟා වේ.

- (i) P_1 හා P_2 අතර ප්‍රත්‍යාගති සංගුණකය $e = \frac{1}{3}$ වේ නම් ගැටුමට පසු P_1 හි ප්‍රවේගය \sqrt{ag} බව පෙන්වන්න.
- (ii) $\beta = \sin^{-1}\left(\frac{3}{4}\right)$ බව පෙන්වා ඉහත ගැටුමෙන් පසු P_2 අංශුව E කරා ළඟාවීමට ගත වන කාලය $\sqrt{\frac{7a}{16g}}$ බව පෙන්වන්න.

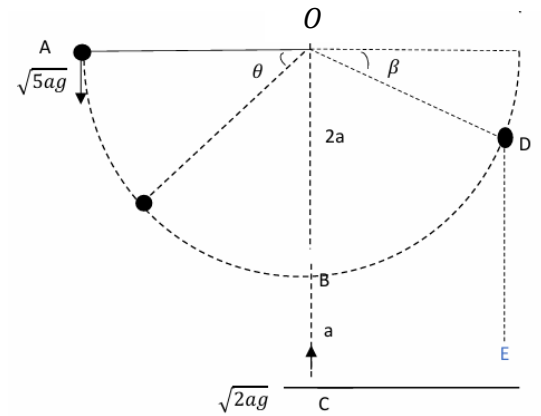

13. ස්වභාවික දිග $2l$ සහ ප්‍රත්‍යාස්ථතා මාපාංකය λ වන සැහැල්ලු ප්‍රත්‍යාස්ථ තන්තුව A නම් අවල ලක්ෂ්‍යයකට සවි කර එහි අනෙක් කෙළවරින් ස්කන්ධය m වූ Q අංශුව එල්ලෙමින් පවතින්නේ, B නම් තවත් අවල ලක්ෂ්‍යයක සිට සිරස්ව $5l$ ඉහලින් A පිහිටන පරිදිය. Q අංශුව සමතුලිතතාවයේ ඇති විට තන්තුවේ දිග $3l$ වේ. $\lambda = 2mg$ බව පෙන්වන්න.

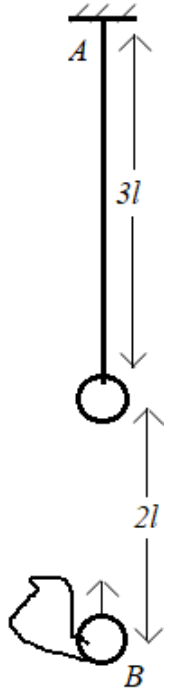

ස්වභාවික දිග l_0 සහ ප්‍රත්‍යාස්ථතා මාපාංකය $2mg$ වන වෙනත් සැහැල්ලු ප්‍රත්‍යාස්ථ තන්තුවක එක් කෙළවරක් ස්කන්ධය m වන P අංශුවකට ගැට ගසා එම තන්තුවේ අනෙක් කෙළවර B ට සම්බන්ධ කර ඇත. P අංශුව B හි සිට $\sqrt{6gl}$ ආරම්භක වේගයෙන් සිරස්ව ඉහලට ප්‍රක්ෂේපනය කෙරේ. P යන්නමින් Q වෙත එළඹේ නම් ශක්ති සංස්ථිතික නියමය භාවිතයෙන් $l_0 = l$ වන බව පෙන්වන්න. $BP = l$ වන විට P හි ප්‍රවේගය සොයන්න.

BP තන්තුවේ දිග $(l + x)$ වන විට P අංශුව සඳහා වලින සමීකරණය $\ddot{x} + \frac{2g}{l} \left(x + \frac{l}{2}\right) = 0$ මගින් දැක්වෙන බව පෙන්වන්න.

$x + \frac{l}{2} = X$ ලෙස ගනිමින් $\ddot{X} + \omega^2 X = 0$ බව පෙන්වන්න. මෙහි ω යනු නිර්ණය කළ යුතු තාත්වික නියතයකි. P හි සරල අනුවර්ති වලිනයේ කේන්ද්‍රය හා විස්තාරය සොයන්න.

p අංශුව Q වෙත පැමිණ එය Q සමග භාවේ. සංයුක්ත S අංශුව B ට ඉහලින් $(l + y)$ උසින් පිහිටන විට S හි වලින සමීකරණය $\ddot{y} + \left(\frac{3g}{2l}\right)y = 0$ මගින් දෙනු ලබන බව පෙන්වන්න. S හි සරල අනුවර්ති වලිනයේ කේන්ද්‍රය හා විස්තාරය සොයන්න.

p අංශුව B හි සිට ප්‍රක්ෂේප කල මොහොතේ සිට, පහළින් ඇති තන්තුව මුල් වරට හැකිලීමට ගතවන මුළු කාලය $\sqrt{\frac{l}{6g}} \left(\pi + 6 - 2\sqrt{6} + \sqrt{3} \cos^{-1} \left(\frac{1}{3}\right)\right)$ වන බව පෙන්වන්න.

14. (a) A, B, C හා D යනු oxy තලයේ වූ ප්‍රතින්ත ලක්ෂ්‍යය 4 කි. සුපුරුදු අංකනයෙන් A හා B ලක්ෂ්‍යවල පිහිටුම් දෛශික පිළිවෙලින් $\mathbf{i} + 3\mathbf{j}$ හා $3\mathbf{i} + 9\mathbf{j}$ වන අතර, $\overrightarrow{BC} = 2\mathbf{i} - 3\mathbf{j}$ හා $\overrightarrow{BD} = 6\mathbf{i} - 9\mathbf{j}$ වේ.

O, A හා B ලක්ෂ්‍ය ඒකරේඛීය බව පෙන්වන්න.

OC හා AD රේඛා E ලක්ෂ්‍යයේදී හමුවේ.

α ධන නියතයක් සඳහා $OE : OC = \alpha : 1$ වේ. $\mathbf{e} = 5\alpha\mathbf{i} + 6\alpha\mathbf{j}$ බව පෙන්වන්න. මෙහි \mathbf{e} මගින් O මූලය අනුබද්ධයෙන් E ලක්ෂ්‍යයේ පිහිටුම් දෛශිකය නිරූපනය කෙරේ.

එමෙන්ම තවත් β ධන නියතයක් සඳහා $AE : AD = \beta : 1$ වේ. \mathbf{e} සඳහා තවත් ප්‍රකාශනයක් β ඇසුරින් ලබා ගන්න.

එනමින්, $\alpha = \frac{3}{7}$ හා $\beta = \frac{1}{7}$ බව පෙන්වන්න.

තව දුරටත් $\angle OBD = \cos^{-1} \left(\frac{7}{\sqrt{130}}\right)$ බව සාධනය කරන්න.

(b) $ABCDEG$ යනු කේන්ද්‍රය O හා පැත්තක දිග a වූ සවිධි ඡඩාසුයකි. ඡඩාසුයේ තලයේ ක්‍රියාකරන විශාලත්ව ඒකක 2, 3, 4, 5 වන බල පිළිවෙළින් AB, BC, CD, DE පාද දිගේ ක්‍රියා කරන අතර විචල්‍ය F බලයක් G හිදී ක්‍රියා කරයි. OX, OY කාටීසිය අක්ෂ පිළිවෙළින් AB හා BD ට සමාන්තරව තෝරාගෙන ඇත. බල පද්ධතියේ සම්ප්‍රයුක්තය R මගින් දැක්වේ.

- (i) $F = 0$ නම් $|R| = 7$ බව පෙන්වා R සම්ප්‍රයුක්තයේ ක්‍රියාරේඛාවේ කාටීසියානු සමීකරණය සොයන්න.
- (ii) R හි ක්‍රියා රේඛාව OD සමග සමපාත වේ නම් එවිට F හි විශාලත්වය හා දිශාව සොයා නිවැරදිව රූපයේ දක්වන්න. තව ද $|R|$ සොයන්න.
- (iii) බල පද්ධතිය යුග්මයකට තුල්‍ය වන පරිදි F තෝරා ගත්තේ නම්, යුග්මයේ සුර්ණය $\frac{21\sqrt{3}a}{2}$ වන බව පෙන්වන්න. AB මත ක්‍රියා කරන බලය ඉවත් කළේ නම් නව පද්ධතියේ සම්ප්‍රයුක්තය අපෝභනය කරන්න.

15.(a) එක එකක දිග $2a$ සහ බර w වූ ඒකාකාර AB, CD, AD දඬු තුනක් සහ බර λw සහ දිග $2a$ වන තවත් ඒකාකාර BC දණ්ඩක් ඒවායේ කෙළවර වලදී සුමටව සන්ධි කර ඇත. සැහැල්ලු අභිතන්‍ය OA තන්තුවක් මගින් රාමු සැකිල්ල O අවල ලක්ෂ්‍යයකින් එල්ලා ඇත. රාමු සැකිල්ලේ සමවතුරසාකාර හැඩය පවත්වා ගැනීමට AB සහ BC දඬුවල මධ්‍ය ලක්ෂ්‍යවලට සැහැල්ලු දණ්ඩක් සම්බන්ධ කර ඇත. රූපයේ දැක්වෙන පරිදි, AC සිරස් වන ලෙස, සිරස් තලයක සැකිල්ල සමතුලිතතාවයේ තබා ඇත්තේ විශාලත්වය w වන තිරස් බලයක් B හිදී යෙදීමෙනි.

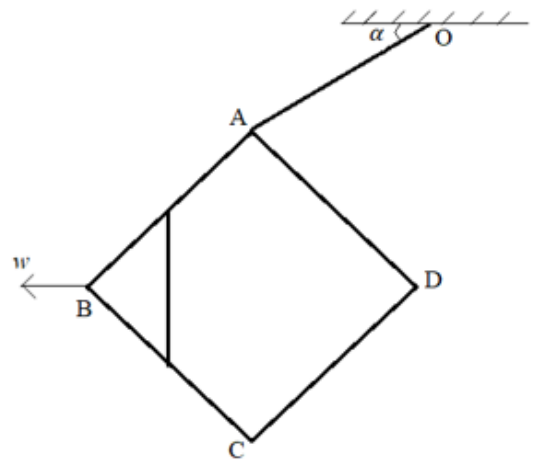

- (i) BC දණ්ඩ මත C හිදී ක්‍රියාකරන ප්‍රතික්‍රියාවේ තිරස් හා සිරස් සංරචක පිළිවෙළින් $\frac{w}{2}$ හා w වන බව පෙන්වන්න.
- (ii) $\lambda = 3$ බව පෙන්වන්න
- (iii) සැහැල්ලු දණ්ඩේ ප්‍රත්‍යාබලය සොයන්න.

(b) රාමු සැකිල්ලක් සැකසීම සඳහා

$2AB = BC = BD = DC$ සහ $\angle BAD = 90^\circ$ වන පරිදි සැහැල්ලු දඬු පහක් සුවලව අසව් කර ඇත. එය A හි දී අවල ලක්ෂ්‍යයකට සුමටව අසව් කර සිරස් තලයක සමතුලිත ව තබා ඇත. රූපයේ දැක්වෙන පරිදි w භාරයක් B වලින් එල්ලා ඇති අතර C හි දී BC ට ලම්බ වූ P බලයක් ද යොදා ඇත.

$$P = \frac{\sqrt{3}}{5} w \text{ බව පෙන්වන්න.}$$

බෝ අංකනය භාවිතයෙන් ප්‍රත්‍යා බල සටහනක් ඇඳ,

ප්‍රත්‍යාබල ආතති හෝ තෙරපුම් ලෙස වෙන් කර දක්වමින් ඒවා සොයන්න.

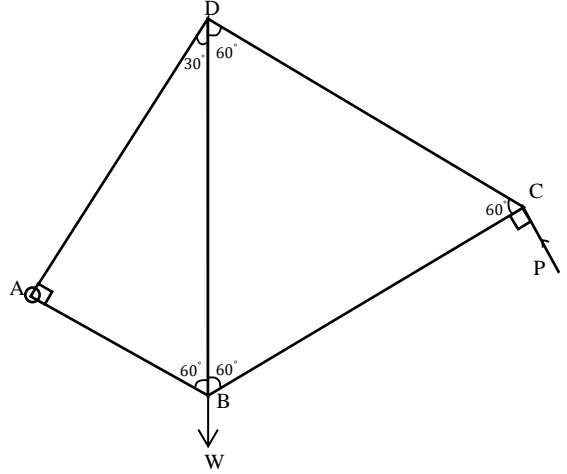

16.(a)I. අරය a වූ තුනී ඒකාකාර අර්ධ ගෝලාකාර කබොලක ස්කන්ධ කේන්ද්‍රය එහි කේන්ද්‍රයේ සිට $\frac{a}{2}$ දුරකින් ද

II. උස h වූ ඒකාකාර කුහර සෘජු වෘත්තාකාර කේතුවක ස්කන්ධ කේන්ද්‍රය එහි පතුලේ කේන්ද්‍රයේ සිට $\frac{1}{3} h$ දුරකින් ද පිහිටන බව පෙන්වන්න.

(b) අරයන් $\frac{a}{2}$ සහ a වූ ද උස $\frac{\sqrt{3}}{2} a$ වූ ද කුහර සෘජු වෘත්තාකාර

ජීන්තකයක හැඩයෙන් යුත් ඒකාකාර තුනී කබොලක මුදුනට, අර්ධ ගෝලාකාර කබොලක් දෘඪව සවි කිරීමෙන් ඔලිම්පික් පහනක් නිමවා ඇත. යාබද රූපයේ දැක්වෙන පරිදි ඒකාකාර සෘජු සිලින්ඩරයක ඉහළ මතු පිටෙහි ජීන්තකය පහත පරිදි දෘඪව පිහිටුවා ඇත.

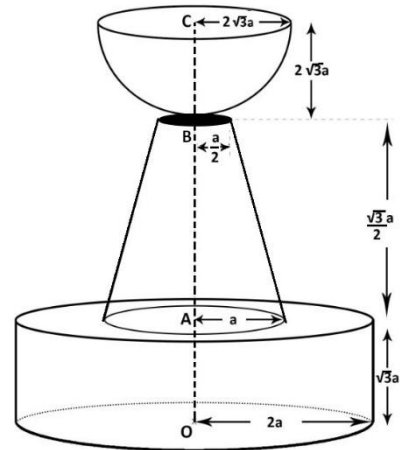

- තුනී ඒකාකාර අර්ධ ගෝලාකාර කබොලෙහි අරය $2\sqrt{3} a$ හා කේන්ද්‍රය C වේ.
- සහ සිලින්ඩරයේ අරය $2a$ හා උස $\sqrt{3} a$ වේ.
- සහ සිලින්ඩරයේ ඒකක පරිමාවක ස්කන්ධය $\frac{2\sigma}{\pi}$ ද ජීන්තකයේ සහ කබොලේ ඒකක වර්ගඵලයක ස්කන්ධය $\frac{a\sigma}{\pi}$ ද වේ.
- සහ වස්තුව සෑදීමට පැස්සීමේදී එහි මුළු ස්කන්ධයන් වෙනස් නොවන බව උපකල්පනය කරන්න.

ඔලිම්පික් පහනේ ස්කන්ධ කේන්ද්‍රයට O සිට දුර $\left(\frac{24\sqrt{3}+371}{48+51\sqrt{3}}\right) a$ බව පෙන්වන්න.

$$\left(\frac{24\sqrt{3}+371}{48+51\sqrt{3}}\right) \approx 3a \text{ ලෙස සලකන්න.}$$

ඔලිම්පික් පහන රළු ආනත තලයක් මත තබා ඇත. ස්පර්ශ මුහුණත ඔලිම්පික් පහන ලිස්සා යාම වැළැකීමට තරම් රළු යැයි උපකල්පනය කර පහත පෙරලීමට ආසන්න වන විට තලයේ ආනතිය සොයන්න.

17. (a) පෙට්ටියක වර්ණයෙන් හැර අන් සියළු අයුරින් සමාන රතු බෝල 4 ක් හා නිල් බෝල 6 ක් අඩංගු වේ. සසම්භාවී ලෙස පෙට්ටියෙන් බෝල දෙකක් ඉවතට ගනු ලබන්නේ එකකට පසු අනෙක වන පරිදිය. පරීක්ෂණය පහත පරිදි සිදු කෙරේ.

- සාධාරණ දාදු කැටයක් උඩ දමා ඉන් ඉරට්ටේ සංඛ්‍යාවක් පෙන්වන්නේ නම්, බෝල ඉවතට ගනු ලබන්නේ ප්‍රතිස්ථාපනය සහිතව ය.
- දාදු කැටයේ ඔත්තේ සංඛ්‍යාවක් පෙන්වන්නේ නම්, බෝල ඉවතට ගනු ලබන්නේ ප්‍රතිස්ථාපනය රහිතවය.

I. ඉවතට ගනු ලබන බෝල දෙකම රතු පාට වීමේ සම්භාවිතාව සොයන්න.

II. ඉවතට ගනු ලබන බෝල දෙකම රතු පාට බව නිරීක්ෂණය කලේ නම්, ප්‍රතිස්ථාපනය රහිතව තෝරා ගැනීම සිදුකිරීමේ සම්භාවිතාව සොයන්න.

(b) k පන්ති ප්‍රාන්තර සංඛ්‍යාවකින් සමන්විත පහත සංඛ්‍යාත ව්‍යාප්තිය සලකා බලමු එහි x_i යනු $i = 1, 2, 3 \dots k$ සඳහා i වන පන්ති ප්‍රාන්තරයේ පන්ති ලකුණ වන අතර f_i යනු i වන පන්ති ප්‍රාන්තරයේ සංඛ්‍යාතය වේ.

පන්ති ලකුණ	සංඛ්‍යාතය
x_1	f_1
x_2	f_2
.....
x_i	f_i
.....
x_k	f_k

මෙම සංඛ්‍යාත ව්‍යාප්තියේ මධ්‍යන්‍යය \bar{x} සහ සම්මත අපගමනය σ ලියන්න.

ක්ෂුද්‍ර ඉතුරුම් සහ ණය දෙන සමාජයක ගනුදෙනුකරුවන් 100 දෙනෙකුගේ වසර පහක් පුරා තැන්පතු පහත වගුවේ දැක්වේ

ඉතුරුම් (රුපියල් 10,000 ඒවා)	ගනුදෙනුකරුවන් ගණන
15-19	10
20-24	20
25-29	f
30- 34	g
35-39	p
40-44	7
එකතුව	100

ව්‍යාප්තියේ මාත පන්තියේ සංඛ්‍යාතය 28 නම් f , මධ්‍යස්ථ පන්තියේ සංඛ්‍යාතය 21 නම් g ,
 මධ්‍යස්ථය < මාතය < 34.5 නම් f ඔබේ පිළිතුරු හේතු දක්වමින් f, g සහ p සොයන්න.

- (i) සාමාජිකයෙකුගේ මධ්‍යස්ථ තැන්පතුව රුපියල් වලින් ගණනය කරන්න
- (ii) රුපියල් 320,000 ක උපකල්පිත මධ්‍යන්‍යයක් භාවිත කරමින්, සාමාජිකයෙකුගේ මධ්‍යන්‍ය තැන්පතුව රුපියල් වලින් ගණනය කරන්න
- (iv) තැන්පතු වල සම්මත අපගමනය, රුපියල් 69,500 ක් බව පෙන්වන්න.
- (v) රුපියල් 395,000 ට අඩුවෙන් තැන්පත් කර ඇති සාමාජිකයින් සංඛ්‍යාව කොපමණද?

1. Using the **Principle of Mathematical Induction**, prove that

$$1.3 + 2.3^2 + 3.3^3 + \dots + n.3^n = \frac{(2n-1)(3)^{n+1}+3}{4} \text{ for all } n \in \mathbb{Z}^+.$$

For $n = 1$; L.H.S = 1.3

$$R.H.S = \frac{(2.1-1)(3)^{1+1}+3}{4} = \frac{(2-1)9+3}{4} = \frac{12}{4} = 3$$

L.H.S = R.H.S \therefore the statement is true for $n = 1$. (5)

Assume that the statement is true for $n = k$; $k \in \mathbb{Z}^+$

$$n = k ; 1.3 + 2.3^2 + 3.3^3 + \dots + k.3^k = \frac{(2k-1)(3)^{k+1}+3}{4}$$

$n = k + 1$ from (1)

$$\begin{aligned} 1.3 + 2.3^2 + 3.3^3 + \dots + k.3^k + (k+1).3^{(k+1)} &= \frac{(2k-1)(3)^{k+1} + 3}{4} + (k+1).3^{(k+1)} \\ &= \frac{(3)^{k+1} [2k-1 + 4(k+1)] + 3}{4} \\ &= \frac{(3)^{k+1} [6k+3] + 3}{4} \\ &= \frac{(3)^{k+1} \cdot 3^1 [2k+1] + 3}{4} \\ &= \frac{(3)^{k+2} \cdot [2(k+1) - 1] + 3}{4} \\ &= \frac{(3)^{(k+1)+1} \cdot [2(k+1) - 1] + 3}{4} \end{aligned}$$

Hence, if the statement is true for $n = k$, then for $n = k + 1$ is also true.

By the principle of mathematical induction, the statement is true for all $n \in \mathbb{Z}^+$. (5)

25

2. Sketch the graphs of $y = |4 - 2|x||$ and $y = 2|x - 1|$ in the same diagram where $x \in \mathbb{R}$. Hence, find the area of the region enclosed by these graphs.

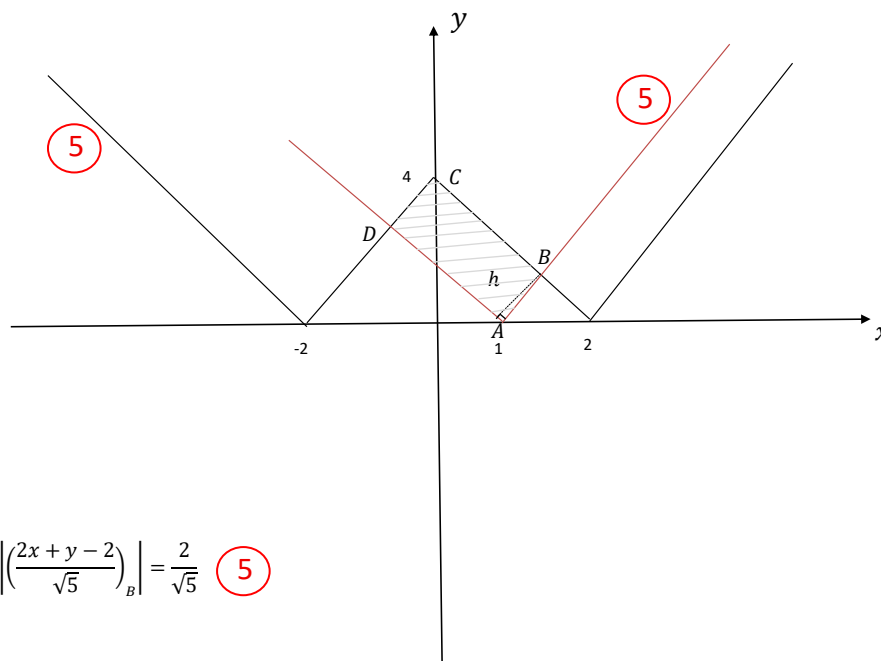

$A \equiv (1,0)$

$B \equiv (\frac{3}{2}, 1)$

$C \equiv (0,4)$

$D \equiv (-\frac{1}{2}, 3)$

$AD \equiv 2x + y - 2 = 0 ; h = \left| \left(\frac{2x + y - 2}{\sqrt{5}} \right)_B \right| = \frac{2}{\sqrt{5}}$ (5)

$d(AD) = \frac{3\sqrt{5}}{2}$ (5)

Area of ABCD = OC \times h = 3 (5)

25

3 Let z, w are two complex numbers such that $|z - 2| = |w + 2| = 1$, then prove that $-\frac{\pi}{6} \leq \text{Arg}(z - w) \leq \frac{\pi}{6}$. Find the range of $|z - w|$.

$\text{Arg}(z - w) = \theta, |z - w| = PQ$

$\Delta OAC \rightarrow \sin \alpha = \frac{1}{2} \Rightarrow \alpha = \frac{\pi}{6}$ (5)

$\text{Arg}(z - w)_{\max} = \alpha$ when P is at C and Q is at F

$\text{Arg}(z - w)_{\min} = -\alpha$ when P is at D and Q is at E

$\therefore -\frac{\pi}{6} \leq \text{Arg}(z - w) \leq \frac{\pi}{6}$ (5)

$PQ_{\max} = NH = 6$

$PQ_{\min} = MG = 2$

$\therefore 2 \leq |z - w| \leq 6$ (5)

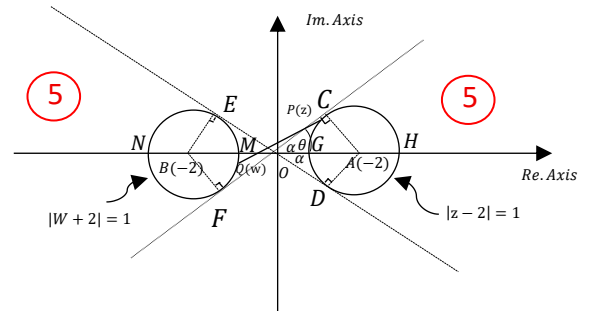

25

4. Write down the binomial expansion of $(x + \frac{1}{x})^n$ in ascending power of x for $n \in \mathbb{Z}^+$. Hence, show that the coefficient of x^2 in the expansion of $((x + \frac{1}{x})^5 + x)^2$ is 231.

Answer:

$(x + \frac{1}{x})^n = \sum_{r=0}^n n_{C_r} x^r (\frac{1}{x})^{n-r}$; where $n_{C_r} = \frac{n!}{r!(n-r)!}$ for $r = 1, 2, \dots, n$ and $n_{C_0} = 1$

$((x + \frac{1}{x})^5 + x)^2 = (x + \frac{1}{x})^{10} + 2x(x + \frac{1}{x})^5 + x^2$

General term of $(x + \frac{1}{x})^{10} = 10_{C_r} \cdot x^r (\frac{1}{x})^{10-r} = 10_{C_r} \cdot x^{2r-10}$

General term of $2x(x + \frac{1}{x})^5 = 2 \times x \times 5_{C_r} \cdot x^r (\frac{1}{x})^{5-r} = 2 \times 5_{C_r} \cdot x^{2r-4}$

Cases for x^2 term,

$10_{C_r} x^{2r-10}$	$2 \times 5_{C_r} \cdot x^{2r-4}$	x^2
$2r - 10 = 2$	$2r - 4 = 2$	
$r = 6$	$r = 3$	
10_{C_6}	$2 \times 5_{C_3}$	1

$\frac{10!}{6! \times 4!} + 2 \times \frac{5!}{2! \times 3!} + 1$

$(\frac{10 \times 9 \times 8 \times 7}{4 \times 3 \times 2 \times 1}) + 2 \times (\frac{5 \times 4}{2 \times 1}) + 1 = 231$ (5)

25

5. Show that $\lim_{x \rightarrow \frac{\pi}{6}} \left(\frac{2 - \sqrt[3]{16 \sin x}}{\sin 6x} \right) = \frac{1}{3\sqrt{3}}$

$$L.H.S = (-1) \lim_{x \rightarrow \frac{\pi}{6}} \left(\frac{(16 \sin x)^{\frac{1}{3}} - 8^{\frac{1}{3}}}{16 \sin x - 8} \right) \cdot \frac{(\pi - 6x)}{\sin(\pi - 6x)} \cdot \frac{16(\sin x - \sin \frac{\pi}{6})}{(\pi - 6x)} \quad (5)$$

$$= (-16) \cdot \lim_{16 \sin x \rightarrow 8} \left(\frac{(16 \sin x)^{\frac{1}{3}} - 8^{\frac{1}{3}}}{16 \sin x - 8} \right) \cdot \lim_{(\pi - 6x) \rightarrow 0} \left(\frac{(\pi - 6x)}{\sin(\pi - 6x)} \right) \cdot \lim_{\left(\frac{x - \frac{\pi}{6}}{2}\right) \rightarrow 0} \left[\frac{2 \cos\left(x + \frac{\pi}{6}\right)}{-12} \cdot \left(\frac{\sin\left(\frac{x - \frac{\pi}{6}}{2}\right)}{\left(\frac{x - \frac{\pi}{6}}{2}\right)} \right) \right] \quad (5)$$

$$= -16 \cdot \frac{1}{3} \cdot 8 \times \frac{1}{(1)} \times \left(\frac{-1}{6}\right) \cdot \frac{\sqrt{3}}{2} \cdot (1) \quad (5)$$

$$= \frac{1}{3\sqrt{3}} \quad (5)$$

25

6. It is given that when $y = (a + x^2) \tan^{-1}\left(\frac{x}{\sqrt{a}}\right)$; $a > 0$, $\frac{dy}{dx} = \sqrt{a} + 2x \tan^{-1}\left(\frac{x}{\sqrt{a}}\right)$.

Let $f(x) = \sqrt{x \tan^{-1}\left(\frac{x}{\sqrt{a}}\right)}$ for $a, x > 0$. Show that the volume of the solid generated, when the region bounded by the curve $y = f(x)$, the x -axis, $x = 0$ and $x = \sqrt{a}$, is rotated about the x -axis by 2π radians is $\pi \left[\frac{a}{4} (\pi - 2) \right]$ cubic units.

$$\text{volume, } V = \pi \int_0^{\sqrt{a}} [f(x)]^2 dx$$

$$= \pi \int_0^{\sqrt{a}} x \tan^{-1}\left(\frac{x}{\sqrt{a}}\right) dx \quad (5)$$

$$\frac{dy}{dx} = \sqrt{a} + 2x \tan^{-1}\left(\frac{x}{\sqrt{a}}\right)$$

$$\therefore \int_0^{\sqrt{a}} \left(\frac{dy}{dx}\right) dx = \int_0^{\sqrt{a}} \sqrt{a} dx + \int_0^{\sqrt{a}} 2x \tan^{-1}\left(\frac{x}{\sqrt{a}}\right) dx \quad (5)$$

$$\int_0^{\sqrt{a}} x \tan^{-1}\left(\frac{x}{\sqrt{a}}\right) dx = \frac{1}{2} [y]_0^{\sqrt{a}} - \frac{1}{2} \sqrt{a} \int_0^{\sqrt{a}} dx \quad (5)$$

$$= \frac{1}{2} \left[(a + x^2) \tan^{-1}\left(\frac{x}{\sqrt{a}}\right) - \sqrt{a}x \right]_0^{\sqrt{a}}$$

$$= \frac{1}{2} \left[\left((a + a) \tan^{-1}\left(\frac{\sqrt{a}}{\sqrt{a}}\right) - \sqrt{a}\sqrt{a} \right) - (0 - 0) \right] \quad (5)$$

$$= \frac{1}{2} \left(2a \frac{\pi}{4} - a \right)$$

$$= \frac{a}{2} \left(\frac{\pi}{2} - 1 \right)$$

$$\text{Volume} = (\pi) \left[\frac{a}{4} (\pi - 2) \right] \text{ cubic units} \quad (5)$$

25

7. An ellipse is given by parametric equation $x = 13 \cos \alpha$, $y = 5 \sin \alpha$. Where, α is a parameter. Show that $\frac{dy}{dx} = -\frac{5}{13} \cot \alpha$ for $\alpha \neq n\pi, \alpha \neq (2n+1)\frac{\pi}{2}, n \in \mathbb{Z}$. Write the equation of tangent and the normal drawn to the curve at the point of parameter α . Let these tangent and normal cut the x -axis at A and B respectively, show that $OA \cdot OB = 144$ where O is the origin.

$$\left. \begin{aligned} x &= 13 \cos \alpha & y &= 5 \sin \alpha \\ \frac{d(x)}{d\alpha} &= -13 \sin \alpha & \frac{d(y)}{d\alpha} &= 5 \cos \alpha \end{aligned} \right\} \textcircled{5}$$

$$\frac{dy}{dx} = \frac{-5 \cos \alpha}{13 \sin \alpha} = -\frac{5}{13} \cot \alpha \quad \textcircled{5}$$

$$\left. \begin{aligned} y - 5 \sin \alpha &= -\frac{5}{13} \cot \alpha (x - 13 \cos \alpha) \\ y - 5 \sin \alpha &= \frac{13}{5} \tan \alpha (x - 13 \cos \alpha) \end{aligned} \right\} \textcircled{5}$$

When $y = 0$ for

$$x_1 = 13 \sin \alpha \times \frac{\sin \alpha}{\cos \alpha} + 13 \cos \alpha = \frac{13 \sin^2 \alpha + 13 \cos^2 \alpha}{\cos \alpha} = \frac{13}{\cos \alpha}, A \equiv \left(\frac{13}{\cos \alpha}, 0 \right) \textcircled{5}$$

$$x_2 = -\frac{25}{13} \cos \alpha + 13 \cos \alpha = \frac{144}{3} \cos \alpha \quad B \equiv \left(\frac{144}{13} \cos \alpha, 0 \right)$$

$$OA \cdot OB = \underbrace{\frac{13}{\cos \alpha} \times \frac{144}{13} \cos \alpha}_{\textcircled{5}} = 144$$

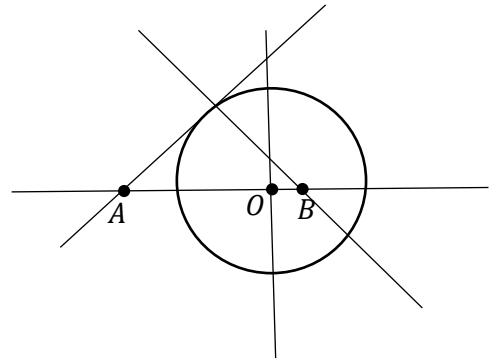

25

8. Let $A \equiv (k, 0)$ where $k \in \mathbb{R} - \{1\}$ and $B \equiv (1, 1)$. The line passing through B , perpendicular to AB , cuts y -axis at C . Find the coordinates of the midpoint D of AC in terms of k and find the locus of D as k varies.

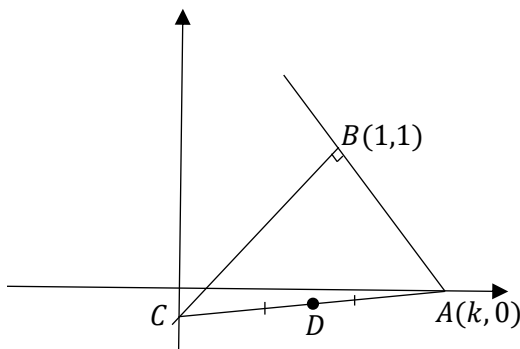

$$m_{AB} = \frac{1-0}{1-k}, \quad k \neq 1$$

$$\therefore m_{BC} = \frac{1}{k-1} \quad \textcircled{5}$$

$$\therefore BC; y - 1 = \frac{1}{(k-1)}(x - 1) \quad \textcircled{5}$$

$$y = (k-1)(x-1) + 1$$

$$y = (k-1)x + (2-k) \quad \textcircled{5}$$

$$\text{when } x = 0, y = (2-k)$$

$$\therefore D = \left(\frac{0+k}{2}, \frac{2-k}{2} \right) = \left(\frac{k}{2}, \frac{2-k}{2} \right) \quad \textcircled{5}$$

$$\text{locus} \Rightarrow x + y - 1 = 0$$

$\textcircled{5}$

25

9. Let S be the circle with equation $x^2 + y^2 - 8x - 10y + 16 = 0$. Another circle S_1 of radius 4 units touches the y -axis at a point above the centre of S . The circles S and S_1 touch internally. Find the equation of S_1 .

$$x^2 + y^2 + 2gx + 2fy + c = 0 \quad (5)$$

$$\sqrt{g^2 + f^2 - c} = 4 \quad | -g | = 4$$

$$g < 0 \Rightarrow g = -4 \quad (5)$$

$$16 + f^2 - c = 16$$

$$c = f^2$$

$$(4 + g)^2 + (5 + f)^2 = 5 - 4 \quad (5)$$

$$0 + (5 + f)^2 = 1$$

$$-f > 5 \Rightarrow f = -6$$

$$c = 36 \quad (5)$$

$$S_1 \equiv x^2 + y^2 - 8x - 12y + 36 = 0 \quad (5)$$

25

10. Solve the equations $x + y = \frac{\pi}{4}$, $\tan x + \tan y = 1$

$$\tan x + \tan y = 1$$

$$\frac{\sin x}{\cos y} + \frac{\sin y}{\cos x} = 1$$

$$\sin x \cos y + \cos x \sin y = \cos x \cos y \quad (5)$$

$$2 \sin(x + y) = \cos(x + y) + \cos(x - y)$$

$$2 \sin\left(\frac{\pi}{4}\right) = \cos\left(\frac{\pi}{4}\right) + \cos(x - y)$$

$$\cos(x - y) = \frac{1}{\sqrt{2}} \quad (5)$$

$$x - y = 2n\pi \pm \frac{\pi}{4} \rightarrow (1) \quad (5)$$

$$x + y = \frac{\pi}{4} \rightarrow (2)$$

$$\text{form (1) and (2) } x = n\pi + \frac{\pi}{4} \text{ or } x = n\pi \quad (5)$$

$$y = -n\pi, n \in \mathbb{Z}, y = -n\pi + \frac{\pi}{4}, n \in \mathbb{Z} \quad (5)$$

25

G.C.E. (A.L) Support Seminar - 2025

සංයුක්ත ගණිතය I
 இணைந்த கணிதம் I
 Combined Mathematics I

10 E I

Part B

* Answer five questions only.

11. (a) Let $f(x) = x^2 - \lambda x + c^2$, where λ and c are real constants. Show that the minimum value of $f(x)$ is $\frac{4c^2 - \lambda^2}{4}$. If the graph of $y = f(x)$ intersects the x -axis at two distinct points,

deduce that $\lambda > 2|c|$.

Let α and β be the roots of $f(x) = 0$. Given that both α and β are positive, show that

$$\sqrt{\alpha} + \sqrt{\beta} = \sqrt{\lambda + 2|c|}.$$

Hence, show that the quadratic equation whose roots are $\sqrt{\alpha} - \frac{1}{\sqrt{\alpha}}$ and $\sqrt{\beta} - \frac{1}{\sqrt{\beta}}$ is given by

$$|c|x^2 - \sqrt{\lambda + 2|c|}(|c| - 1)x + c^2 - \lambda + 1 = 0.$$

$$\text{Let } g(x) = |c|x^2 - \sqrt{\lambda + 2|c|}(|c| - 1)x + c^2 - \lambda + 1.$$

If the graphs of $y = f(x)$ and $y = g(x)$ intersect on the y -axis, show that $\lambda = 1$.

- (b) Let $f(x)$ is a polynomial of degree 3. When $f(x)$ is divided by $x^2 - 3x + 2$, $x^2 - 5x + 6$ and $x^2 - 4x + 3$ separately, the remainder is $11x - 6$. If $f(0) = 0$, find $f(x)$.

Further **deduce** that maximum value of the gradient of $y = f(x)$ is 12.

11. (a).

$$f(x) = x^2 - \lambda x + c^2$$

$$f(x) = \left(x - \frac{\lambda}{2}\right)^2 + \frac{4c^2 - \lambda^2}{4}$$

$$\left(x - \frac{\lambda}{2}\right)^2 \geq 0 \quad (5)$$

$$\left(x - \frac{\lambda}{2}\right)^2 + c^2 - \frac{\lambda^2}{4} \geq \frac{4c^2 - \lambda^2}{4}$$

$$f(x) \geq \frac{4c^2 - \lambda^2}{4}$$

$$\therefore f(x)_{\text{minimum}} = \frac{4c^2 - \lambda^2}{4} \quad (5)$$

If graph of $y = f(x)$ intersects the x -axis at two distinct points, $\frac{4c^2 - \lambda^2}{4} < 0 \quad (10)$

$$\therefore 4c^2 < \lambda^2$$

$$(2c - \lambda)(2c + \lambda) < 0$$

$$\lambda > 2|c| \quad (5)$$

$$\alpha + \beta = \lambda \quad (5) \quad \alpha\beta = c^2, c \neq 0 \quad (5)$$

$$(\sqrt{\alpha} + \sqrt{\beta})^2 = \alpha + \beta + 2\sqrt{\alpha\beta} \quad (5)$$

$$(\sqrt{\alpha} + \sqrt{\beta}) = \sqrt{\lambda + 2|c|} \quad (5)$$

20

$$\begin{aligned} \left(\sqrt{\alpha} - \frac{1}{\sqrt{\alpha}}\right) + \left(\sqrt{\beta} - \frac{1}{\sqrt{\beta}}\right) &= (\sqrt{\alpha} + \sqrt{\beta}) - \frac{(\sqrt{\alpha} + \sqrt{\beta})}{\sqrt{\alpha\beta}} \\ &= \frac{(\sqrt{\alpha} + \sqrt{\beta})}{\sqrt{\alpha\beta}} (\sqrt{\alpha\beta} - 1) \quad (5) \\ &= \frac{\sqrt{\lambda+2|c|}}{|c|} (|c| - 1) \quad (5) \end{aligned}$$

$$\begin{aligned} \left(\sqrt{\alpha} - \frac{1}{\sqrt{\alpha}}\right) \cdot \left(\sqrt{\beta} - \frac{1}{\sqrt{\beta}}\right) &= \sqrt{\alpha\beta} - \frac{\sqrt{\alpha}}{\sqrt{\beta}} - \frac{\sqrt{\beta}}{\sqrt{\alpha}} + \frac{1}{\sqrt{\alpha\beta}} \quad (5) \\ &= \sqrt{\alpha\beta} - \frac{(\sqrt{\alpha} + \sqrt{\beta})}{\sqrt{\alpha\beta}} + \frac{1}{\sqrt{\alpha\beta}} \\ &= |c| - \frac{\lambda}{|c|} + \frac{1}{|c|} \\ &= \frac{c^2 - \lambda + 1}{|c|} \quad (5) \end{aligned}$$

Required quadratic equation

$$x^2 - \left\{ \left(\sqrt{\alpha} - \frac{1}{\sqrt{\alpha}}\right) + \left(\sqrt{\beta} - \frac{1}{\sqrt{\beta}}\right) \right\} x + \left(\sqrt{\alpha} - \frac{1}{\sqrt{\alpha}}\right) \left(\sqrt{\beta} - \frac{1}{\sqrt{\beta}}\right) = 0 \quad (10)$$

$$x^2 - \frac{\sqrt{\lambda+2|c|}}{|c|} (|c| - 1)x + \frac{c^2 - \lambda + 1}{|c|} = 0 \quad (5)$$

$$|c|x^2 - \sqrt{\lambda + 2|c|} (|c| - 1)x + c^2 - \lambda + 1 = 0$$

35

If the graphs of $y = f(x)$ and $y = g(x)$ intersect on y -axis, then $f(0) = g(0)$ (5)

$$c^2 = c^2 - \lambda + 1$$

$$\lambda = 1 \quad (5)$$

10

11. (b) $F(x) \equiv k(x-1)(x-2)(x-3) + 11x - 6; k \in \mathbb{R}$ (15)

$$f(0) = 0$$

$$k(-1)(-2)(-3) - 6 = 0$$
 (5)

$$k = (-1)$$
 (5)

$$F(x) \equiv -1(x-1)(x-2)(x-3) + 11x - 6$$
 (5)

$$F(x) \equiv -x^3 + 6x^2$$
 (5)

35

$$F'(x) = -3x^2 + 12x$$
 (10)

$$= -3(x^2 - 4x)$$

$$= -3[(x-2)^2 - 4]$$
 (5)

$$= 12 - 3(x-2)^2$$
 (5)

$$\therefore [F'(x)]_{\text{maximum}} = 12$$
 (5)

25

12. (a) Let P_1, P_2 and P_3 be three sets given by $P_1 = \{\alpha, \beta, \gamma\}$, $P_2 = \{A, B, C\}$, $P_3 = \{1, 3, 5\}$ respectively. It is required to form a **five**-character password using elements belongs to $P_1 \cup P_2 \cup P_3$.

- (i) Find the number of different element passwords that can be formed using above different elements
- I. when there are no restrictions on the selection
 - II. consisting exactly two digits

- (ii) Find the number of different passwords that can be formed using above elements such that exactly one element from P_1 and exactly two elements from P_2 with repetitions allowed only for elements from P_3

(b) Let $U_r = \frac{9(3r+4)}{(3r-1)(3r+2)(3r+5)}$ and $f(r) = \frac{A}{(3r-1)} + \frac{B}{(3r+2)}$ for $r \in \mathbb{Z}^+$, where A and B are real constants.

Let $U_r = f(r) - f(r+1)$ for $r \in \mathbb{Z}^+$, show that $A = \frac{5}{2}$ and $B = \frac{1}{2}$.

Hence, show that $\sum_{r=1}^n U_r = \frac{27}{20} - \frac{5}{2(3n+2)} - \frac{1}{2(3n+5)}$; $n \in \mathbb{Z}^+$.

Deduce that the infinite series $\sum_{r=1}^{\infty} U_r$ is convergent and find its sum.

Hence, find the greatest real constant k such that $\sum_{r=1}^{\infty} (U_r + kU_{r+2}) \leq 1$

12. (a) (i) $P_1 = \{\alpha, \beta, \gamma\}$ $P_2 = \{A, B, C\}$ $P_3 = \{1, 3, 5\}$

i. when there are no restriction on the selection

$$= {}^9C_5 \times 5! = \frac{9!}{4! \times 5!} = 15,120$$

10

ii. when selecting 2 digit exactly;

$$= {}^6C_3 \times 3C_2 \times 5!$$

$$= \frac{6!}{3! \times 3!} \times 3! \times 5! = \frac{6 \times 5 \times 4 \times 120 \times 3}{3 \times 2 \times 2} = 7200$$

Alter method

P_1	P_2	P_3
1	2	2
2	1	2
3	0	2
0	3	2

$$3C_1 \times {}^3C_2 \times 3C_1 \times 5!$$

$$3C_2 \times {}^3C_1 \times 3C_2 \times 5!$$

$$3C_3 \times {}^3C_0 \times 3C_2 \times 5!$$

$$3C_0 \times {}^3C_3 \times 3C_2 \times 5!$$

Total different Password = $2 \times 3 \times 3 \times 3 \times 5! + 2 \times 1 \times 1 \times 3 \times 5! = 7200$

15

(ii)

P_1	P_2	P_3
1	2	two different
1	2	two equal

$$\Rightarrow 3C_1 \times {}^3C_2 \times 3C_2 \times 5!$$

$$\Rightarrow 3C_1 \times {}^3C_2 \times 3C_1 \times \frac{5!}{2!}$$

$$\therefore \text{total number of different passwords} \left\{ \begin{aligned} &= 3C_1 \times {}^3C_2 \times \left[{}^3C_2 + \frac{3C_1}{2} \right] \times 5! \end{aligned} \right.$$

$$= 3 \times 3 \left[3 + \frac{3}{2} \right] \times 5 \times 4 \times 3$$

$$= 9 \times \frac{9}{2} \times 60$$

$$= 81 \times 30 = 2430$$

45

(b) $U_r = f(r) - f(r + 1)$

$$\frac{9(3r+4)}{(3r-1)(3r+2)(3r+5)} = \frac{A}{(3r-1)} + \frac{B}{(3r+2)} - \frac{A}{(3r+2)} - \frac{B}{(3r+5)} \quad (05)$$

$$9(3r + 4) \equiv A(3r + 2)(3r + 5) + (B - A)(3r - 1)(3r + 5) - B(3r - 1)(3r + 2)$$

$$\equiv (9A + 9B)r + 15A - 3B \quad (05)$$

$$r; 27 = 9A + 9B \rightarrow (1) \quad (05)$$

$$3 = A + B$$

$$r^0; 36 = 15A - 3B \rightarrow (2) \quad (05)$$

(1), (2)

$$45 = 18A$$

$$A = \frac{5}{2}$$

$$B = \frac{1}{2}$$

20

$$\therefore f(r) = \frac{5}{2(3r-1)} + \frac{1}{2(3r+2)} \quad (05)$$

$$u_r = f(r) - f(r + 1)$$

$$r = 1;$$

$$u_1 = f(1) - f(2)$$

$$r = 2;$$

$$u_2 = f(2) - f(3) \quad (05)$$

$$r = 3;$$

$$u_3 = f(3) - f(4)$$

.....

.....

.....

$$r = n - 2;$$

$$u_{n-2} = f(n-2) - f(n-1)$$

$$r = n - 1;$$

$$u_{n-1} = f(n-1) - f(n) \quad (05)$$

$$r = n;$$

$$u_n = f(n) - f(n+1)$$

$$\sum_{r=1}^n u_r = f(1) - f(n+1) \quad (05)$$

$$= \frac{5}{4} + \frac{1}{10} - \frac{5}{2[3(n+1)-1]} - \frac{1}{2[3(n+1)+2]} \quad (05)$$

$$= \frac{27}{20} - \frac{5}{2(3n+2)} - \frac{1}{2(3n+5)} \quad (05)$$

30

$$\begin{aligned} \textcircled{05} \quad \lim_{n \rightarrow \infty} \sum_{r=1}^n U_r &= \lim_{n \rightarrow \infty} \left[\frac{27}{20} - \frac{5}{2(3n+2)} - \frac{1}{2(3n+5)} \right] \\ &= \frac{27}{20} \quad \textcircled{05} \end{aligned}$$

\therefore the infinite series $\sum_{r=1}^{\infty} U_r$ is convergent and the sum = $27/20$ $\textcircled{05}$

$$\sum_{r=1}^{\infty} u_r$$

15

$$\sum_{r=1}^{\infty} (U_r + kU_{r+2}) \leq 1$$

$$\sum_{r=1}^{\infty} U_r + k\{[U_3 + U_4 + U_5 + \dots] + U_1 + U_2\} - kU_1 - kU_2 \leq 1$$

From u_r ,

$$(1+k) \sum_{r=1}^{\infty} U_r - k(U_1 + U_2) \leq 1 \quad \textcircled{05}$$

$$U_1 = \frac{9 \times 7}{2 \times 5 \times 8}$$

$$(1+k) \frac{27}{20} - k \left(\frac{9}{5 \times 8} \left(\frac{7}{2} + \frac{10}{11} \right) \right) \leq 1$$

$$U_2 = \frac{9 \times 10}{5 \times 8 \times 11}$$

$$(1+k) \frac{27}{20} - k \left(\frac{9}{40} \times \frac{97}{22} \right) \leq 1$$

$$\frac{27}{20} + \left(\frac{27}{20} - \frac{9}{40} \times \frac{97}{22} \right) k \leq 1$$

$$\frac{27}{20} + \frac{9k}{20} \left(3 - \frac{97}{44} \right) \leq 1 \quad \textcircled{05}$$

$$27 + \frac{9k}{44} \times 35 \leq 20$$

$$9k \times \frac{35}{44} \leq -7$$

$$k \leq -\frac{44}{45}$$

\therefore Greatest value of $k = -\frac{44}{45}$ $\textcircled{05}$

15

13. (a) (i) Let $(\mathbf{PQ})^T = \mathbf{Q}^T \mathbf{P}^T$ for two matrices \mathbf{P}, \mathbf{Q} and \mathbf{A}, \mathbf{B} be two square matrices of same order.

If \mathbf{A} is a symmetric matrix, prove that $\mathbf{B}^T \mathbf{A} \mathbf{B}$ is symmetric and if \mathbf{A} is skew symmetric $\mathbf{B}^T \mathbf{A} \mathbf{B}$ is skew symmetric.

(ii) Let the matrix $\mathbf{A}(x) = (1 - x^2)^{-\frac{1}{2}} \begin{pmatrix} 1 & x \\ x & 1 \end{pmatrix}$ for $x \in \mathbb{R}$, where $|x| < 1$.

Given that $\mathbf{A}(x)\mathbf{A}(y) = \mathbf{A}(z)$, determine z in terms of x and y . Using a suitable substitution for z find the inverse matrix of $\mathbf{A}(x)$.

(b) Point P represents a complex number z , where $z = r(\cos \theta + i \sin \theta)$; $r > 0, -\pi < \theta \leq \pi$ in an Argand diagram. Provide geometric constructions for the point Q which represent z^2 .

Draw the locus described by $|1 + z| = 1$, hence find z such that $|z + 1| = 1$ and $|z^2 + 1| = 1$.

(c) Let $\omega = \cos \frac{2\pi}{5} + i \sin \frac{2\pi}{5}$. Using **De Moivre's theorem**, find ω^5 .

Prove that $1 + \omega + \omega^2 + \omega^3 + \omega^4 = 0$.

Hence, find the value of $\cos \frac{\pi}{5} - \cos \frac{2\pi}{5}$.

13(a) (i). If A is symmetric $A^T = A$ (05)

$$\begin{aligned} (B^T A B)^T &= B^T A^T (B^T)^T \\ &= B^T A B \quad (05) \end{aligned}$$

$\therefore B^T A B$ is a symmetric matrix

If A is skew symmetric $A^T = -A$ (05)

$$\begin{aligned} (B^T A B)^T &= B^T A^T (B^T)^T \\ &= B^T (-A) B \\ &= -B^T A B \quad (05) \end{aligned}$$

$\therefore B^T A B$ is a skew symmetric matrix

$$(ii.) |x| < 1 \Rightarrow (1 - x^2)^{-\frac{1}{2}} \in \mathbb{R}^+ \quad (05)$$

$$\begin{aligned} A(x)A(y) &= (1 - x^2)^{-\frac{1}{2}} \begin{pmatrix} 1 & x \\ x & 1 \end{pmatrix} (1 - y^2)^{-\frac{1}{2}} \begin{pmatrix} 1 & y \\ y & 1 \end{pmatrix} \\ &= (1 - x^2 - y^2 + x^2y^2)^{-\frac{1}{2}} \begin{pmatrix} 1 & x \\ x & 1 \end{pmatrix} \begin{pmatrix} 1 & y \\ y & 1 \end{pmatrix} \quad (05) \\ &= (1 + xy)(1 - x^2 - y^2 + x^2y^2)^{-\frac{1}{2}} \begin{pmatrix} 1 & \frac{x+y}{1+xy} \\ \frac{x+y}{1+xy} & 1 \end{pmatrix} \quad (05) \\ &= \left(\frac{(1+xy)^2 - (x+y)^2}{(1+xy)^2} \right)^{-\frac{1}{2}} \begin{pmatrix} 1 & \frac{x+y}{1+xy} \\ \frac{x+y}{1+xy} & 1 \end{pmatrix} \\ &= \left(1 - \left(\frac{x+y}{1+xy} \right)^2 \right)^{-\frac{1}{2}} \begin{pmatrix} 1 & \frac{x+y}{1+xy} \\ \frac{x+y}{1+xy} & 1 \end{pmatrix} \quad (05) \end{aligned}$$

$$\begin{aligned} A(x)A(y) &= (1 - z^2)^{-1/2} \begin{pmatrix} 1 & z \\ z & 1 \end{pmatrix} \quad (05) \\ &= A(z) \end{aligned}$$

$$\text{Where } z = \frac{x+y}{1+xy} \quad (05)$$

$$1 - z^2 = 1 - \left(\frac{x+y}{1+xy} \right)^2 = \frac{(1-x^2)}{(1+xy)^2} > 0$$

$$\therefore |z| < 1$$

30

$$\text{Let } z = 0 \Rightarrow x + y = 0 \Rightarrow y = -x \quad (05)$$

$$A(x)A(-x) = \begin{pmatrix} 1 & 0 \\ 0 & 1 \end{pmatrix} \quad (05)$$

$$A^{-1}(x) = A(-x)$$

$$= (1 - x^2)^{-\frac{1}{2}} \begin{pmatrix} 1 & -x \\ x & 1 \end{pmatrix} \quad (05)$$

15

(b)

$$\text{Let } z = r(\cos \theta + i \sin \theta)$$

$$z^2 = r^2(\cos \theta + i \sin \theta)^2$$

$$z^2 = r^2(\cos 2\theta + i \sin 2\theta) \quad (05)$$

Point Q is marked on the line l such that $O\hat{A}P = O\hat{P}Q$

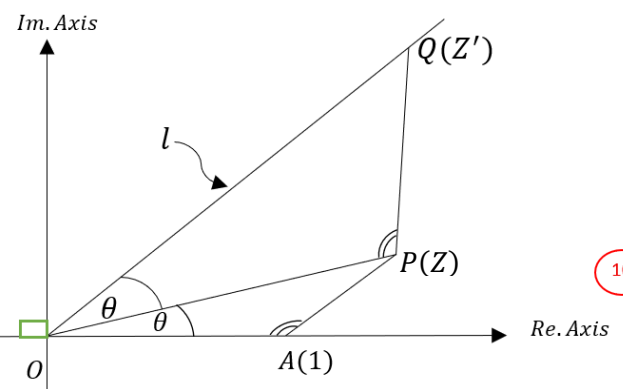

OAP and OPQ are similar triangles

$$\frac{OQ}{OP} = \frac{OP}{OA}$$

$$OQ = OP^2 = r^2 \quad (05)$$

$$\text{Arg}(z') = 2\theta, \quad |z'| = r^2$$

$$\therefore z' = z^2$$

20

Let $z = r(\cos \theta + i \sin \theta)$, $OP = r$

$$OA = AP = AQ = 1, OQ = r^2 \quad (05)$$

$$OP = 2OA \cos(\pi - \theta) = -2 \cos \theta$$

$$r = -2 \cos \theta \rightarrow (1) \quad (05)$$

$$OQ = 2OA \cos(2\theta - \pi) = 2 \cos(\pi - 2\theta)$$

$$r^2 = -2 \cos 2\theta \rightarrow (2) \quad (05)$$

$$(1), (2) \Rightarrow 4 \cos^2 \theta = -2 \cos 2\theta$$

$$1 + \cos 2\theta = -\cos 2\theta$$

$$\cos 2\theta = -\frac{1}{2} \Rightarrow 2\theta = \pm 120^\circ$$

$$\theta = \pm 60^\circ \Rightarrow r = -2 \cos(\pm 60^\circ) = 1 \quad (05)$$

$$z = 1[\cos(\pm 60^\circ) + i \sin(\pm 60^\circ)] = \frac{1}{2} \pm \frac{\sqrt{3}}{2}i \quad (05)$$

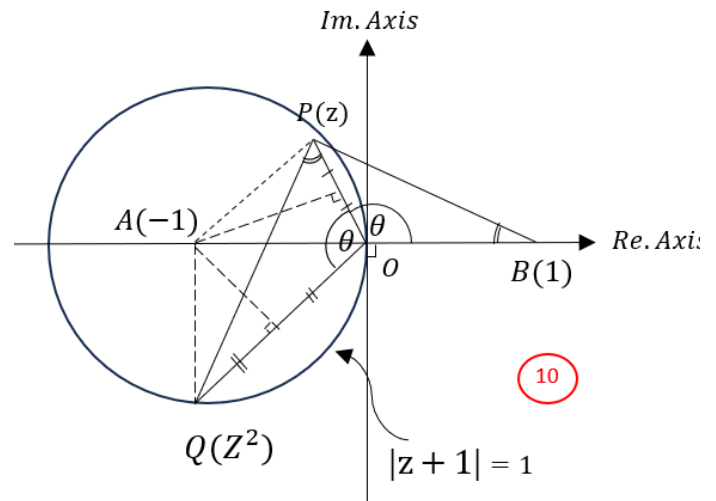

(10)

40

$$\begin{aligned} 13(c) \Rightarrow x^5 - 1 &= (x-1)(x^4 + x^3 + x^2 + x + 1) \\ \omega^5 - 1 &= (\omega-1)(\omega^4 + \omega^3 + \omega^2 + \omega + 1) \\ \omega &\neq 1 \quad (05) \\ 1 + \omega + \omega^2 + \omega^3 + \omega^4 &= 0 \end{aligned}$$

$$\omega = \cos \frac{2\pi}{5} + i \sin \frac{2\pi}{5} \quad (05)$$

$$\begin{aligned} \omega^2 &= \left(\cos \frac{2\pi}{5} + i \sin \frac{2\pi}{5} \right)^2 = \cos \frac{4\pi}{5} + i \sin \frac{4\pi}{5} = \cos \left(\pi - \frac{\pi}{5} \right) + i \sin \left(\pi - \frac{\pi}{5} \right) \\ &= -\cos \frac{\pi}{5} + i \sin \frac{\pi}{5} \end{aligned}$$

$$\omega^3 = \left(\cos \frac{2\pi}{5} + i \sin \frac{2\pi}{5} \right)^3 = \cos \frac{6\pi}{5} + i \sin \frac{6\pi}{5} = \cos \left(\pi + \frac{\pi}{5} \right) + i \sin \left(\pi + \frac{\pi}{5} \right) = -\cos \frac{\pi}{5} - i \sin \frac{\pi}{5} \quad (05)$$

$$\omega^4 = \left(\cos \frac{2\pi}{5} + i \sin \frac{2\pi}{5} \right)^4 = \cos \frac{8\pi}{5} + i \sin \frac{8\pi}{5} = \cos \left(2\pi - \frac{2\pi}{5} \right) + i \sin \left(2\pi - \frac{2\pi}{5} \right) = \cos \frac{2\pi}{5} - i \sin \frac{2\pi}{5} \quad (05)$$

$$1 + \omega + \omega^2 + \omega^3 + \omega^4 = 0$$

$$1 + \cos \frac{2\pi}{5} + i \sin \frac{2\pi}{5} - \cos \frac{\pi}{5} + i \sin \frac{\pi}{5} - \cos \frac{\pi}{5} - i \sin \frac{\pi}{5} + \cos \frac{2\pi}{5} - i \sin \frac{2\pi}{5} = 0$$

$$\cos \frac{\pi}{5} - \cos \frac{2\pi}{5} = \frac{1}{2} \quad (05)$$

25

14. (a) Let $f(x) = \frac{x(x-4)}{(x+4)^2}$ for $x \in \mathbb{R} - \{-4\}$

Show that $f'(x) = \frac{4(3x-4)}{(x+4)^3}$, for $x \neq -4$, where $f'(x)$ is the first derivative of $f(x)$.

Hence, find the intervals on which $f(x)$ is increasing and the interval on which $f(x)$ is decreasing. Sketch the graph of $y = f(x)$ indicating asymptotes, turning points, and points of intersection on the x , y axes.

It is given that $f''(x) = \frac{-24(x-4)}{(x+4)^4}$; $x \neq -4$.

Show that $(4,0)$ is the point of inflection of $y = f(x)$.

Deduce the graph of

$$y = \frac{x(x+4)}{(x+8)^2}; \text{ for } x < -8$$

- (b) The adjoining figure shows a cheese wedge consisting two identical plane faces OAB and DCE which are sectors of a circle of radius r cm with sector angle α radians, where $0 < \alpha < \frac{\pi}{2}$. The three edges OD , BE , and AC are all perpendicular to both faces giving the solid appearance as shown in figure with thickness of h cm. Given that the volume of the cheese wedge is 9 cm^3 , show that the surface area of the wedge is given by $S = r^2\alpha + \frac{18(2+\alpha)}{r\alpha}$. Find $\frac{ds}{dr}$. **Hence**, find r such that the area S is minimum for $\alpha = 1$ radians.

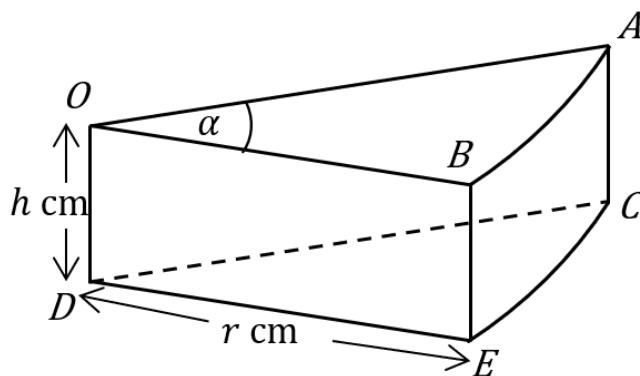

14(a) for $x \neq -4$, $f(x) = \frac{x(x-4)}{(x+4)^2}$ (05)

$$f'(x) = \frac{(x+4)^2 \frac{d(x^2-4x)}{dx} - x(x-4) \frac{d(x+4)^2}{dx}}{(x+4)^4}$$
 (05)

$$f'(x) = \frac{(x+4)^2(2x-4) - x(x-4) \cdot 2(x+4)}{(x+4)^4}$$

$$f'(x) = \frac{2(x+4)[(x+4)(x-2) - x^2 + 4x]}{(x+4)^4}$$
 (05)

$$f'(x) = \frac{2(x^2 + 2x - 8 - x^2 + 4x)}{(x+4)^3}$$

$$f'(x) = \frac{4(3x-4)}{(x+4)^3}$$

15

When $\lim_{x \rightarrow -\infty} f(x) = 1$ } $y = 1$ is a horizontal asymptote (05)

when $\lim_{x \rightarrow +\infty} f(x) = 1$ }

when $\lim_{x \rightarrow -4^-} f(x) = +\infty$ } $\therefore x = -4$ is a vertical asymptote (05)

when $\lim_{x \rightarrow -4^+} f(x) = +\infty$ }

when $x = 0, y = 0$ (05)

when $y = 0, x = 0$ or $x = 4$ (05) when $f'(x) = 0 \Rightarrow x = 4/3$ (05)

25

x	$x < -4$	$-4 < x < \frac{4}{3}$	$x > 4$
sign of $f'(x)$	+	-	+
function	Increasing	decreasing	Increasing

when $x = \frac{4}{3}$, $f(x)$ has a relative Minimum $y = -\frac{1}{8}$
Minimum point $(\frac{4}{3}, -\frac{1}{8})$ (05)

15

20

when $f''(x) = 0$, there may be a point of inflection
 $x = 4, y = 0$ (05)

x	$x < -4$	$-4 < x < 4$	$x > 4$
sign of $f''(x)$	-	-	+
concavity	down	down	up

Concavity changes at $x = 4$.

$\therefore (4, 0)$ is a point of inflection. (05)

$$y = \frac{x(x+4)}{(x+8)} = \frac{(x+4-4)(x+4)}{(x+4+4)}$$

$$X = x + 4$$

05

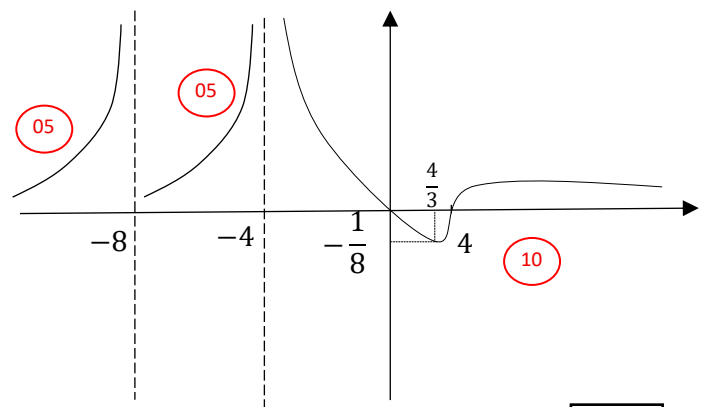

10

45

(b)

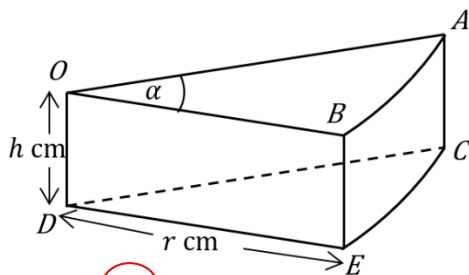

$$S = 2hr + \frac{1}{2}r^2\alpha \times 2 + 2\pi r \times \frac{\alpha}{2\pi} \times h$$

$$\therefore S = 2hr + r^2\alpha + \alpha rh$$

But the volume of the

$$\text{cheese wedge } 9 = \pi r^2 \times \frac{\alpha}{2\pi} h \Rightarrow h = \frac{18}{\alpha r^2}$$

$$\therefore S = 2r \times \frac{18}{\alpha r^2} + r^2\alpha + \alpha r \cdot \frac{18}{\alpha r^2} = \frac{36}{\alpha r} + r^2\alpha + \frac{18}{r} = \frac{18}{r\alpha}(\alpha + 2) + r^2\alpha$$

$$\frac{d(S)}{dr} = \frac{18(\alpha+2)}{\alpha} \cdot (-1) \frac{1}{r^2} + 2r\alpha$$

$$\frac{d(S)}{dr} = 0, \alpha = 1 \quad \frac{3 \times 18}{1} \cdot \frac{1}{r^2} = 2 \times 1 \times r \Rightarrow r^3 = 27, \therefore r = 3 \text{ cm}$$

r	$0 < r < 3$	$r > 3$
$\frac{ds}{dr}$	-	+

$r = 3$

45

15. (a) Find the values of the constants A, B and C such that $x^2 + 2 \equiv A(x^2 - 2x + 4) + (Bx + C)(x + 2)$ for all $x \in \mathbb{R}$,

Hence, integrate $\int \frac{x^2 + 2}{x^3 + 8} dx$

- (b) By using a suitable substitution prove that $\int_a^b f(x) dx = \int_a^b f(a + b - x) dx$, where a and b are constants.

$$\text{Let } I = \int_{\frac{\pi}{3}}^{\frac{2\pi}{3}} \frac{\sin x}{\cos x - \sin x} dx. \quad \text{Show that } I = \int_{\frac{\pi}{3}}^{\frac{2\pi}{3}} \frac{-\sin x}{\cos x + \sin x} dx.$$

$$\text{Deduce that } \int_{\frac{\pi}{3}}^{\frac{2\pi}{3}} \tan 2x dx = 0$$

Find the values of constants λ and μ such that $\sin x = \lambda(\cos x - \sin x) - \mu(\cos x + \sin x)$,

show that $I = \ln\left(\frac{\sqrt{3}-1}{\sqrt{2}}\right) - \frac{\pi}{6}$.

- (c) Let $y = \sec^2 x - \tan x$. Find $\frac{dy}{dx}$.

$$\text{Hence, evaluate. } \int_0^{\frac{\pi}{3}} \sec^2 x (\tan x - 1) dx$$

$$(a) \quad x^2 + 2 = A(x^2 - 2x + 4) + (Bx + c)(x + 2)$$

$$x^2 \Rightarrow A + B = 1 \rightarrow (1)$$

$$x^1 \Rightarrow -2A + 2B + C = 0 \rightarrow (2)$$

$$x^0 \Rightarrow 4A + 2C = 2 \rightarrow (3)$$

$$A = B = \frac{1}{2} \quad (5) \quad C = 0 \quad (5)$$

$$\begin{aligned} \therefore \int \frac{x^2+2}{x^3+8} dx &= \int \frac{A(x^2-2x+4)+Bx(x+2)}{x^3+8} dx \\ &= A \int \frac{(x^2-2x+4)}{(x+2)(x^2-2x+4)} dx + B \int \frac{x(x+2)}{(x+2)(x^2-2x+4)} dx \end{aligned}$$

$$= A \int \frac{1}{x+2} dx + B \int \frac{x}{x^2-2x+4} dx \quad (5)$$

$$= A \ln|x+2| + B \frac{1}{2} \int \frac{2x-2+2}{x^2-2x+4} dx \quad (5)$$

$$= A \ln|x+2| + \frac{B}{2} \int \frac{2x-2}{x^2-2x+4} dx + B \int \frac{1}{x^2-2x+4} dx$$

$$= A \ln|x+2| + \frac{B}{2} \ln|x^2-2x+4| + B \int \frac{1}{\sqrt{3}^2+(x-1)^2} dx$$

$$= \frac{1}{2} \ln|x+2| + \frac{1}{4} \ln|x^2-2x+4| + \frac{1}{2\sqrt{3}} \tan^{-1}\left(\frac{x-1}{\sqrt{3}}\right) + \lambda \quad (5)$$

50

$$(b) \quad \int_a^b f(x) dx = \int_a^b f(a+b-x) dx \quad \text{proof}$$

$$\text{Let } x = a + b - X$$

$$\therefore dx = -dX$$

$$\left. \begin{array}{l} (x = a) \\ (X = b) \end{array} \right\} \quad \left. \begin{array}{l} (x = b) \\ (X = a) \end{array} \right\} \quad (5)$$

$$\int_a^b f(x) dx = \int_b^a f(a+b-X)(-dX)$$

$$= - \int_b^a f(a+b-X) dX \quad (5)$$

$$= \int_a^b f(a+b-X) dX$$

$$\int_a^b f(x) dx = \int_a^b f(a+b-x) dx$$

(5)

15

$$I = \int_{\frac{\pi}{3}}^{\frac{2\pi}{3}} \frac{\sin x}{\cos x - \sin x} dx = \int_{\frac{\pi}{3}}^{\frac{2\pi}{3}} \frac{\sin x \left(\frac{\pi+2\pi}{3}-x\right)}{\cos\left(\frac{\pi+2\pi}{3}-x\right) - \sin\left(\frac{\pi+2\pi}{3}-x\right)} dx \quad (5)$$

$$= \int_{\frac{\pi}{3}}^{\frac{2\pi}{3}} \frac{\sin x}{-\cos x - \sin x} dx = \int_{\frac{\pi}{3}}^{\frac{2\pi}{3}} \frac{-\sin x}{\cos x + \sin x} dx \quad (5)$$

$$\int_{\frac{\pi}{3}}^{\frac{2\pi}{3}} \frac{\sin x}{\cos x - \sin x} dx + \int_{\frac{\pi}{3}}^{\frac{2\pi}{3}} \frac{\sin x}{\cos x + \sin x} dx = 0$$

$$\int_{\frac{\pi}{3}}^{\frac{2\pi}{3}} \frac{\sin x(\cos x + \sin x) + \sin x(\cos x - \sin x)}{(\cos x - \sin x)(\cos x + \sin x)} dx = 0$$

$$\int_{\frac{\pi}{3}}^{\frac{2\pi}{3}} \frac{2\sin x \cos x}{\cos^2 x - \sin^2 x} dx = 0 \Rightarrow \int_{\frac{\pi}{3}}^{\frac{2\pi}{3}} \tan 2x dx = 0$$

15

$$\sin x = \lambda(\cos x - \sin x) - \mu(\cos x + \sin x)$$

$$\left. \begin{array}{l} \sin x \Rightarrow -\lambda - \mu = 1 \\ \cos x \Rightarrow \lambda - \mu = 0 \end{array} \right\} \lambda = \mu = -\frac{1}{2}$$

$$I = \int_{\frac{\pi}{3}}^{\frac{2\pi}{3}} \frac{\sin x}{\cos x - \sin x} dx$$

$$I = \int_{\frac{\pi}{3}}^{\frac{2\pi}{3}} \frac{\lambda(\cos x - \sin x) - \mu(\cos x + \sin x)}{\cos x - \sin x} dx$$

$$I = \lambda \int_{\frac{\pi}{3}}^{\frac{2\pi}{3}} dx + \mu \int_{\frac{\pi}{3}}^{\frac{2\pi}{3}} \frac{-\cos x - \sin x}{\cos x - \sin x} dx$$

$$= [\lambda x + \mu \ln|\cos x - \sin x|]_{\frac{\pi}{3}}^{\frac{2\pi}{3}}$$

$$= -\frac{1}{2} \left[\left(\frac{2\pi}{3} - \frac{\pi}{3} \right) + \ln \left| \frac{\cos \frac{2\pi}{3} - \sin \frac{2\pi}{3}}{\cos \frac{\pi}{3} - \sin \frac{\pi}{3}} \right| \right]$$

$$= -\frac{1}{2} \left[\frac{\pi}{3} + \ln \left| \frac{\frac{1}{2} \frac{\sqrt{3}}{2}}{\frac{1}{2} \frac{\sqrt{3}}{2}} \right| \right]$$

$$= -\frac{1}{2} \ln \left(\frac{\sqrt{3}+1}{\sqrt{3}-1} \right) - \frac{\pi}{6}$$

$$= \frac{1}{2} \ln \left(\frac{\sqrt{3}-1}{\sqrt{3}+1} \right) - \frac{\pi}{6}$$

$$= \frac{1}{2} \ln \left(\frac{(\sqrt{3}-1)^2}{(\sqrt{3}+1)(\sqrt{3}-1)} \right) - \frac{\pi}{6}$$

$$= \frac{1}{2} \ln \left(\frac{\sqrt{3}-1}{\sqrt{2}} \right)^2 - \frac{\pi}{6} = \ln \left(\frac{\sqrt{3}-1}{\sqrt{2}} \right) - \frac{\pi}{6}$$

35

(C) $y = \sec^2 x - \tan x$

$$\frac{dy}{dx} = 2 \sec x \sec x \tan x - \sec^2 x$$

$$= \sec^2 x (2 \tan x - 1)$$

$$I = \int_0^{\frac{\pi}{3}} \sec^2 x (\tan x - 1) dx$$

$$= \frac{1}{2} \int_0^{\frac{\pi}{3}} \sec^2 x (2 \tan x - 2) dx$$

$$= \frac{1}{2} \int_0^{\frac{\pi}{3}} \sec^2 x (2 \tan x - 1 - 1) dx$$

$$\begin{aligned}
&= \frac{1}{2} \int_0^{\frac{\pi}{3}} \sec^2 x (2 \tan x - 1) dx - \frac{1}{2} \int_0^{\frac{\pi}{3}} \sec^2 x dx \\
&= \frac{1}{2} [y]_0^{\frac{2\pi}{3}} - \frac{1}{2} [\tan x]_0^{\frac{2\pi}{3}} \\
&= \frac{1}{2} [\sec^2 x - \tan x]_0^{\frac{\pi}{3}} - \frac{1}{2} (\tan \frac{\pi}{3} - \tan 0) \\
&= \frac{1}{2} [(2)^2 - \sqrt{3}] - [(1)^2 - 0] - \frac{\sqrt{3}}{2} \\
&= \frac{1}{2} [3 - \sqrt{3} - \sqrt{3}] \\
&= \frac{\sqrt{3}}{2} (\sqrt{3} - 2)
\end{aligned}$$

35

- 16.** Let $A \equiv (1,2)$ is on the line $l \equiv ax + by - 3 = 0$ where $a, b \in \mathbb{R}$ and the parametric equation of the line l is given by $x = 2t + 1, y = t + 2$ where t is a parameter. Find the values of a and b .
- Let the circle $S \equiv x^2 + y^2 - 4x - 5y + 9 = 0$ cuts the line l at A and B . Find the coordinates of the point B .
- Show that the centre of the circle S lies on l and find the equations of tangents drawn from A to the circle S_1 with centre B and radius $\frac{\sqrt{10}}{2}$.
- Find the angle between one of the above tangents and line l and find the area bounded by the above two tangents and the common chord of the circles S and S_1 .

$$l; ax + by - 3 = 0$$

Passing through $A \equiv (1,2)$

$$a + 2b + 3 = 0$$

$$a + 2b = -3 \rightarrow (1)$$

Parametric form $2t + 1, t + 2$

$$\text{Gradient } \frac{t+2-2}{2t+1-1} = -\frac{a}{b}$$

$$\frac{t}{2t} = -\frac{a}{b}$$

$$2a + b = 0 \rightarrow (2)$$

$$(1) \times 2 - (2) \Rightarrow 3b = 6 \Rightarrow b = 2$$

$$a = +1$$

$$\therefore l \equiv x - 2y + 3 = 0$$

20

$$S = x^2 + y^2 - 4x - 5y + 9 = 0$$

$$\text{Centre } \left(2, \frac{5}{2}\right) \quad (5)$$

$$x - 2y = 2 - 2 \times \frac{5}{2} + 3 = 0 \quad (5)$$

\therefore centre on $l = 0$

$$\text{Coordinates of } B = \frac{2 \times 2 - 1 \times 1}{2 - 1}, \frac{2 \times \frac{5}{2} - 1 \times 2}{2 - 1} = (3, 3) \quad (5)$$

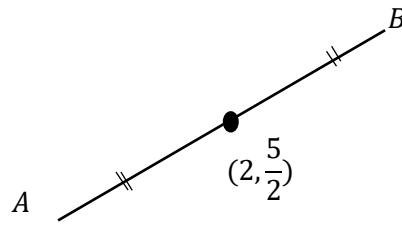

20

let $m_{AP} = m$

$$\therefore AP; \frac{y-2}{x-1} = m \quad (5)$$

$$y - 2 = mx - m$$

$$mx - y + (2 - m) = 0 \quad (5)$$

\perp distance from B to AP

$$\frac{|m(3) - 3 + (2 - m)|}{\sqrt{m^2 + 1}} = \frac{\sqrt{10}}{2}$$

$$\frac{|3m - 3 + 2 - m|}{\sqrt{m^2 + 1}} = \frac{\sqrt{10}}{2}$$

$$(5) \quad \frac{|2m - 1|}{\sqrt{m^2 + 1}} = \frac{\sqrt{10}}{2} \quad (5)$$

$$4(2m - 1)^2 = 10(m^2 + 1)$$

$$16m^2 - 16m + 4 = 10m^2 + 10$$

$$6m^2 - 16m - 6 = 0$$

$$3m^2 - 8m - 3 = 0 \quad (5)$$

$$(3m + 1)(m - 3) = 0$$

$$m = -\frac{1}{3} \text{ or } m = 3 \quad (5)$$

\therefore Equation of tangents are

$$m = -\frac{1}{3} \Rightarrow -\frac{1}{3}x - y + 2 + \frac{1}{3} = 0$$

$$x + 3y - 7 = 0 \quad (5)$$

$$m = 3 \Rightarrow 3x - y + (2 - 3) = 0$$

$$3x - y - 1 = 0 \quad (5)$$

50

Angle between, $l = 0$ and $3x - y - 1 = 0$

let the angle is θ

$$\tan \theta = \left| \frac{m_1 - m_2}{1 + m_1 m_2} \right| \quad (5)$$

$$= \left| \frac{\frac{1}{2} - 3}{1 + \frac{1}{2}(3)} \right| = 1 \quad (5)$$

$$\theta = 45^\circ \quad (5)$$

these two tangents are \perp to each other

\therefore Angle between, $l = 0$ and one of the tangent is 45°

5

25

$$S_1 = (x-3)^2 + (y-3)^2 = \left(\frac{\sqrt{10}}{2}\right)^2 \quad 5$$

$$x^2 + y^2 - 6x - 6y + 18 - \frac{10}{4} = 0$$

$$S_1 = x^2 + y^2 - 6x - 6y + \frac{31}{2} = 0$$

$$S = x^2 + y^2 - 4x - 5y + 9 = 0$$

equation of common chord

$$S - S_1 = 0$$

$$2x + y - \frac{13}{2} = 0 \quad 5$$

$$P; x + y - \frac{13}{2} = 0 \rightarrow 1$$

$$x + 3y - 7 = 0 \rightarrow 2$$

$$2 - 1 \Rightarrow 2y - \frac{1}{2} = 0$$

$$y = \frac{1}{4} \quad 5 \quad \therefore x = \frac{25}{4} \quad 5$$

$$P = \left(\frac{25}{4}, \frac{1}{4}\right)$$

$$AP^2 = \left(\frac{25}{4} - 1\right)^2 + \left(\frac{1}{4} - 2\right)^2 \quad 5$$

$$= \left(\frac{21}{4}\right)^2 + \left(-\frac{7}{4}\right)^2$$

$$= \frac{441+49}{16} = \frac{490}{16} \quad 5$$

$$AP = \frac{7}{4}\sqrt{10}$$

$$\therefore \text{Area} = \frac{1}{2} \times \left(\frac{7}{4}\sqrt{10}\right)^2$$

$$= \frac{49 \times 10}{2 \times 16} = \frac{245}{16} \text{ sq. units} \quad 5$$

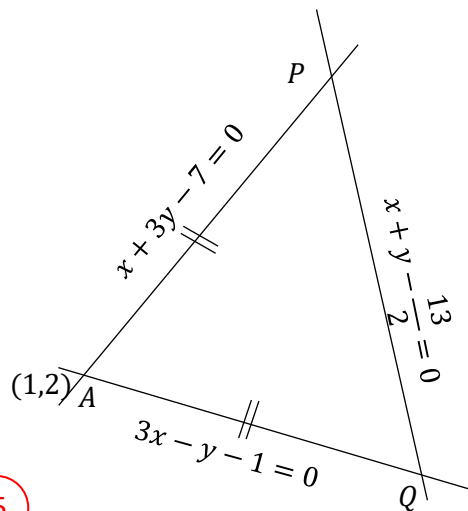

35

17. (a) Prove that $\cot \theta \equiv \operatorname{cosec} 2\theta + \cot 2\theta$ for $\theta \neq \frac{n\pi}{2}$ and $n \in \mathbb{Z}$. **Hence**, show that $\cot \frac{\pi}{12} = 2 + \sqrt{3}$.

Hence, find $\operatorname{cosec}^2 \frac{\pi}{12}$. Determine x and y positive integers such that $\operatorname{cosec} \frac{\pi}{12} = \sqrt{x} + \sqrt{y}$.

Deduce the value of $\tan \frac{\pi}{24}$

(b) In the usual notation, state and prove the **Sine rule** for any triangle.

In a triangle ABC , it is given that $BC = 5$ cm, $AC = 4$ cm, and $A = \frac{\pi}{2} + B$. Show that $\tan C = \frac{9}{40}$.

Hence, find $\sin B$ and length AB . The internal bisector of the angle $B\hat{A}C$ meets the side BC at D . Find length BD .

(c) Solve $\cos^{-1}(1-x) = 2 \sin^{-1} x$.

$$\operatorname{cosec} 2\theta + \cot 2\theta \equiv \frac{1}{\sin 2\theta} + \frac{\cos 2\theta}{\sin 2\theta} \equiv \frac{1+2\cos^2\theta-1}{2\sin\theta\cos\theta} \equiv \cot \theta \quad (05)$$

$$\cot \theta = \operatorname{cosec} 2\theta + \cot 2\theta$$

$$\text{when } \theta = \frac{\pi}{12}, \quad \cot \frac{\pi}{12} = \operatorname{cosec} \frac{\pi}{6} + \cot \frac{\pi}{6} = 2 + \sqrt{3} \quad (05)$$

$$\operatorname{cosec}^2 \frac{\pi}{12} = 1 + \cot^2 \frac{\pi}{12} = 1 + (2 + \sqrt{3})^2 \quad (05)$$

$$\operatorname{cosec} \frac{\pi}{12} = \sqrt{8 + 4\sqrt{3}} \quad (05)$$

$$\sqrt{8 + 4\sqrt{3}} = \sqrt{x} + \sqrt{y}$$

$$8 + 2\sqrt{12} = x + y + 2\sqrt{xy}$$

$$\therefore x + y = 8 \rightarrow (1) \quad (05)$$

$$xy = 12 \rightarrow (2) \quad (05)$$

By solving (1) and (2)

$$x = 2 \rightarrow y = 6$$

$$x = 6 \rightarrow y = 2 \quad (05)$$

$$\therefore \sqrt{8 + 4\sqrt{3}} = \sqrt{2} + \sqrt{6}$$

$$\operatorname{cosec} \frac{\pi}{12} = \sqrt{2} + \sqrt{6}$$

$$\cot \frac{\pi}{12} = 2 + \sqrt{3}$$

$$\therefore \tan \frac{\pi}{12} = \frac{1}{2 + \sqrt{3}}$$

$$\tan \frac{\pi}{12} = 2 - \sqrt{3}$$

$$\cot \theta = \operatorname{cosec} 2\theta + \cot 2\theta$$

(05)

$$\tan \theta = \frac{1}{(\operatorname{cosec} 2\theta + \cot 2\theta)} \cdot \frac{(\operatorname{cosec} 2\theta - \cot 2\theta)}{(\operatorname{cosec} 2\theta - \cot 2\theta)}$$

$$\tan \theta = \frac{(\operatorname{cosec} 2\theta - \cot 2\theta)}{(\operatorname{cosec}^2 2\theta + \cot^2 2\theta)}$$

$$\tan \theta = (\operatorname{cosec} 2\theta - \cot 2\theta) \quad (05)$$

$$\text{when } \theta = \frac{\pi}{24}, \tan \frac{\pi}{24} = \operatorname{cosec} \frac{\pi}{12} - \cot \frac{\pi}{12}$$

$$\tan \frac{\pi}{24} = \sqrt{2} + \sqrt{6} - (2 + \sqrt{3})$$

$$\tan \frac{\pi}{24} = \sqrt{2} - \sqrt{3} + \sqrt{6} - \sqrt{2} \quad (05)$$

60

(b)

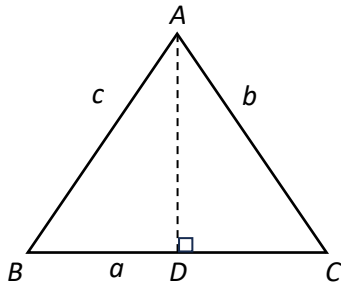

(i) ABC is an acute angled triangle.

$$AD = AB \sin B = AC \sin C$$

$$\therefore \frac{b}{\sin B} = \frac{c}{\sin C} \quad (05)$$

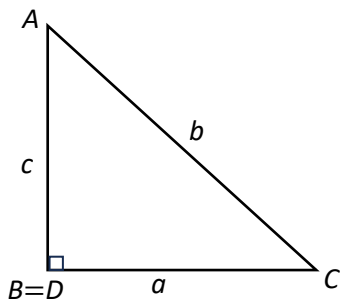

(ii) ABC is a right angled triangle.

$$AD = AB \sin B = AC \sin C$$

$$\therefore \frac{b}{\sin B} = \frac{c}{\sin C} \quad (05)$$

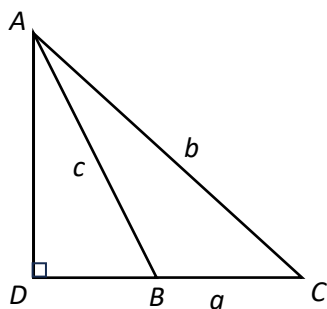

(iii) ABC is an obtuse angled triangle.

$$AD = AB \sin(\pi - B) = AC \sin C$$

$$\therefore \frac{b}{\sin B} = \frac{c}{\sin C} \quad (05)$$

$$\text{Similarly, we can show } \frac{a}{\sin A} = \frac{c}{\sin C} \quad (05)$$

$$\therefore \frac{a}{\sin A} = \frac{b}{\sin B} = \frac{c}{\sin C}$$

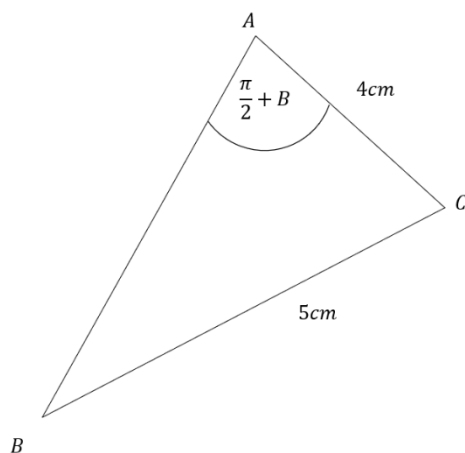

$$\frac{4}{\sin B} = \frac{5}{\sin\left(\frac{\pi}{2}+B\right)} \quad (05)$$

$$\frac{4}{5} = \tan B \quad (05)$$

$$A + B + C = \pi$$

$$\frac{\pi}{2} + B + B + C = \pi$$

$$C = \frac{\pi}{2} - 2B \quad (05)$$

$$\tan C = \tan\left(\frac{\pi}{2} - 2B\right)$$

$$= \cot 2B \quad (05)$$

$$= \frac{1 - \tan^2 B}{2 \tan B} = \frac{1 - 16/25}{8/5}$$

$$\tan C = 9/40$$

$$\tan B = \frac{4}{5} \Rightarrow \sin B = \frac{4}{\sqrt{41}} \quad (05)$$

$$\text{Let } AB = x$$

$$\frac{x}{\sin C} = \frac{4}{\sin B} \quad (10)$$

$$\frac{x}{\sin\left(\frac{\pi}{2} - 2B\right)} = \frac{4}{\sin B}$$

$$\frac{x}{\cos 2B} = \frac{4}{\sin B}$$

$$\frac{x}{9} = \frac{4}{\sin B}$$

$$\frac{41x}{9} = \frac{4\sqrt{41}}{4}$$

$$x = \frac{9}{\sqrt{41}} \text{ cm}$$

$$\therefore AB = \frac{9}{\sqrt{41}} \text{ cm} \quad (05)$$

Using angle bisector theorem

$$\frac{AB}{AC} = \frac{BD}{DC} \quad (05)$$

$$\frac{9}{4\sqrt{41}} = \frac{BD}{5 - BD} \quad (05)$$

$$\frac{9}{4\sqrt{41}} = \frac{BD}{5 - BD}$$

$$BD = \frac{45}{9 + 4\sqrt{41}} \quad (05)$$

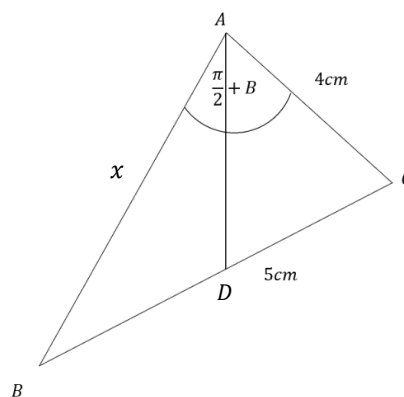

$$(c) \quad \cos^{-1}(1-x) = 2 \sin^{-1}(x)$$

$$1-x = \cos 2 \sin^{-1}(x) \quad (05)$$

$$1-x = 1 - 2 \sin^2 \sin^{-1}(x)$$

$$1-x = 1 - 2x^2 \quad (05)$$

$$2x^2 - x = 0$$

$$x(2x-1) = 0$$

$$x = 0, x = 1/2 \quad (05)$$

15

Part A

1. Two particles A and B of masses km and m respectively are moving along a smooth horizontal table towards each other with speeds $2u$ and u respectively, collide directly. The coefficient of restitution between A and B is e . Just after the collision, if they move with equal speeds in the opposite directions, show that $e = \frac{2(2k-1)}{3(1-k)}$. Hence deduce that $\frac{1}{2} < k \leq \frac{5}{7}$

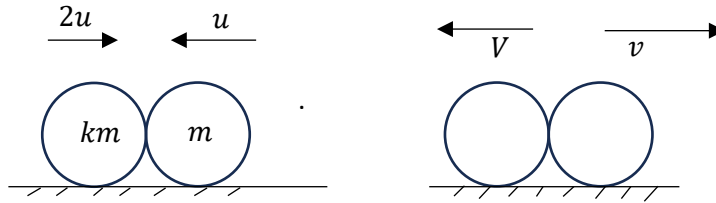

Applying $I = \Delta mv$ for the system

$$\rightarrow 0 = mv - kmv - (2kmu - mu) \quad (5)$$

$$(1 - k)v = (2k - 1)u$$

$$v = \left(\frac{2k - 1}{1 - k}\right)u$$

Newton's Experiment law

$$(v + v) = e(2u + u) \quad (5)$$

$$3eu = \frac{2(2k - 1)u}{1 - k}$$

$$e = \frac{2(2k - 1)}{3(1 - k)} \quad (5)$$

$$0 < e \leq 1$$

$$0 < \frac{2(2k - 1)}{3(1 - k)} \leq 1 \quad (5)$$

$$\frac{2(2k - 1)}{3(1 - k)} > 0 \Rightarrow \frac{1}{2} < k < 1$$

$$\frac{2(2k - 1)}{3(1 - k)} - 1 \leq 0$$

$$\frac{7k - 5}{3(1 - k)} \leq 0$$

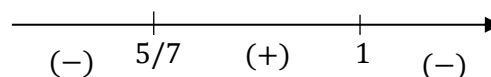

$$\therefore \frac{1}{2} < k \leq \frac{5}{7} \quad (5)$$

2. A bomb B is released from an aero-plane which is flying horizontally with the velocity u and at a constant height h . When it is released from rest and at the same time a bullet A is fired from a point which is vertically below the aero-plane. It is given that the bullet is fired at an angle θ to the horizontal to blast the bomb after time t . show that $t = \frac{h}{u} \cot \theta$

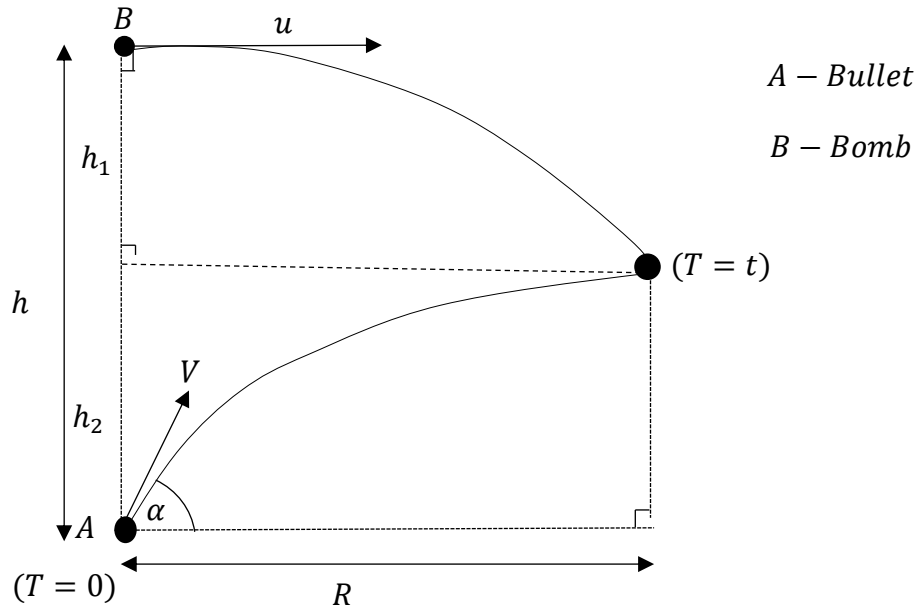

$$S = ut + \frac{1}{2}at^2$$

$$(B); \downarrow h_1 = \frac{gt^2}{2} \rightarrow (1) \quad (5)$$

$$(A); \uparrow h_2 = V \cdot \sin \alpha t - \frac{gt^2}{2} \rightarrow (2) \quad (5)$$

$$(B); \rightarrow R = ut \rightarrow (3)$$

$$(A); \rightarrow R = V \cos \alpha \cdot t \rightarrow (4) \quad (5)$$

$$(3), (4) \Rightarrow V = \frac{u}{\cos \alpha} \quad (5)$$

$$(1) + (2) \Rightarrow h_1 + h_2 = V \sin \alpha t$$

$$h = \sin \alpha \cdot \frac{u}{\cos \alpha} \cdot t \Rightarrow t = \frac{h}{u} \cdot \cot \alpha \quad (5)$$

3. As shown in the figure, a particle P of mass m lies on a **rough** plane inclined at α to the horizontal. It is connected by a light inextensible string passing over two smooth pulleys to a particle Q of mass m on another **smooth** plane inclined at α to the horizontal. Another light inextensible string attached to Q , passes over a smooth pulley and is attached to a particle R of mass $3m$ hanging freely. The coefficient of friction between P and the plane is μ . The system is released from rest, and P moves up the plane. Write down the equations of motion sufficient to determine the tensions in the strings and the accelerations of the particles.

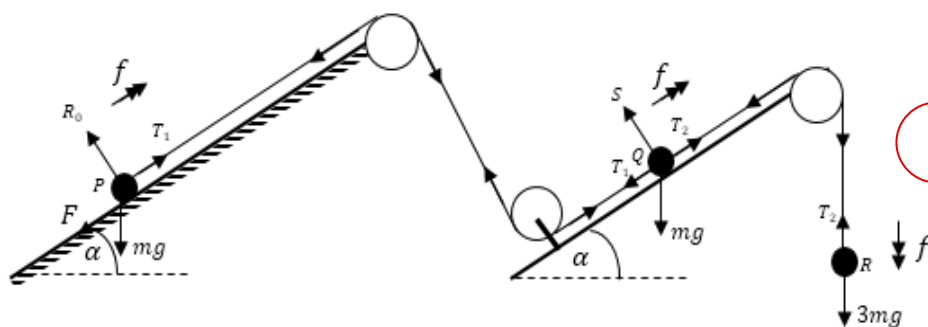
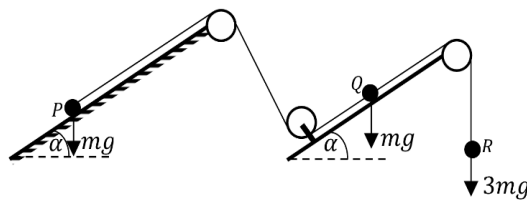

5 Forces & Accelerations

$$F = ma$$

$$\text{For P} \quad T_1 - F - mg \sin \alpha = mf \quad 5$$

$$\nearrow R_0 - mg \cos \alpha = 0$$

$$F = \mu R_0 \quad 5$$

$$\text{For Q} \quad T_2 - T_1 - mg \sin \alpha = mf \quad 5$$

$$\text{For R} \quad \downarrow 3mg - T_2 = 3mf \quad 5$$

4. A train mass M kg moves along a horizontal track at a uniform velocity. The rear compartment m kg ($< M$) of the train deattach and the engine driver is informed after it moves ℓ km after the detachment. At this moment the engine driver stops the engine. If the resistance to the motion of the train is uniform and proportional to the weight of the train then show that the distance between the rear compartment and the train is $\frac{M}{M-m} \ell$ when the both parts become at rest by considering the power exerted by the engine is constant. Assume that after the detachment of the compartment the engine continue the same tractive force until the driver disconnects the engine.

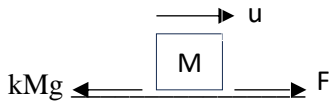

k is a constant

for train $\underline{F} = m\underline{a}$ \longrightarrow

$$F - kMg = M \cdot 0$$

$$F = kMg$$

5

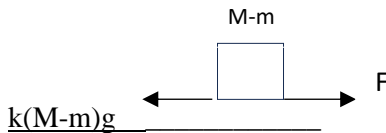

For train (without last compartment)

$$\longrightarrow \underline{F} = m\underline{a}$$

$$F - k(M-m)g = (M-m) a$$

$$kMg - k(M-m)g = (M-m) a$$

let acceleratem of the train , a

5

$$\frac{kmg}{M-m} = a$$

For train

$$\longrightarrow v^2 = u^2 + 2as$$

$$w^2 = u^2 + 2 \frac{kmg}{M-m} \ell$$

5

for the train

$$\longrightarrow \underline{F} = m\underline{a}$$

$$-k(M-m)g = (M-m) a$$

$$-kg = a^2$$

for train

$$\longrightarrow v^2 = u^2 + 2as$$

$$0 = u^2 + 2 \frac{kmg}{M-m} \ell - 2kg S_1$$

$$S_1 = \frac{u^2}{2kg} + \frac{m}{M-m} \ell$$

5

for the last compartment

$$v^2 = u^2 + 2as$$

$$S_2 = \frac{u^2}{2kg} \quad (5)$$

$$\text{Distance } c \text{ between the train and last compartment} = S_1 - S_2 = \frac{m}{M-m} \ell$$

25

5. A particle P of mass m is attached to an end of a light inextensible string of length a and the other end of the string is tied to a fixed-point O . When the particle hangs freely a horizontal velocity of \sqrt{ga} is given. Show that the tension in the string is $\frac{1}{2}mg$ when the particles comes to instantaneous rest.

$$(T.E)_B = (T.E)_A$$

$$-mga \cos \theta = \frac{1}{2}mga - mga \quad (15)$$

$$\cos \theta = 1 - \frac{1}{2}$$

$$= \frac{1}{2}$$

$$\hookrightarrow T - mg \cos \theta = 0 \quad (10)$$

$$T = mg \times \frac{1}{2}$$

$$= \frac{mg}{2}$$

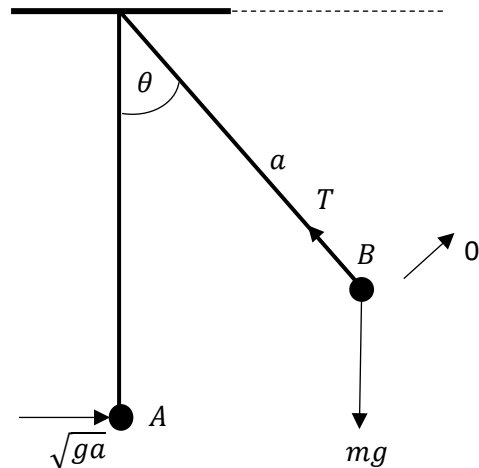

25

6. In usual notation, let the position vector of point A be $\mathbf{a} = 3\mathbf{i} + \mathbf{j}$. Point B has position vector $3\mathbf{a}$. O is the origin and P is the midpoint of OB . A point C lies on the x -axis such that $\angle PCB = \frac{\pi}{2}$. Show that $|\overrightarrow{OC}| = 6$ or $|\overrightarrow{OC}| = \frac{15}{2}$.

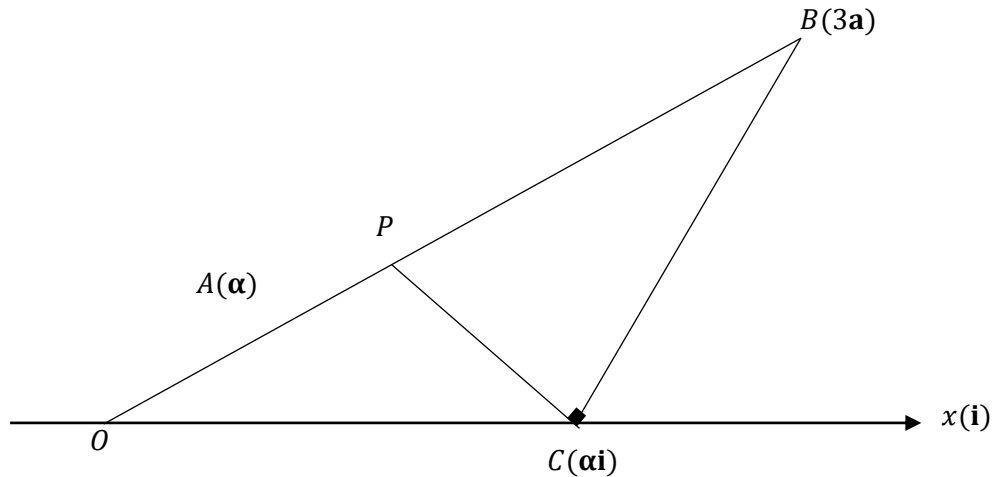

$$\overrightarrow{OP} = \mathbf{p} = \frac{1}{2}\overrightarrow{OB} = \frac{3\mathbf{a}}{2} = \frac{3}{2}(3\mathbf{i} + \mathbf{j})$$

Point C on the X -axis

$$\overrightarrow{OC} = \alpha\mathbf{i} \quad (5)$$

$$\overrightarrow{CP} = \mathbf{p} - \mathbf{c} = \frac{3}{2}(3\mathbf{i} + \mathbf{j}) - \alpha\mathbf{i}$$

$$= \left(\frac{9}{2} - \alpha\right)\mathbf{i} + \frac{3}{2}\mathbf{j}$$

$$\overrightarrow{CB} = \mathbf{b} - \mathbf{c} = 3\mathbf{a} - \mathbf{c} = 3(3\mathbf{i} + \mathbf{j}) - \alpha\mathbf{j}$$

$$= (9 - \alpha)\mathbf{i} + 3\mathbf{j} \quad (5)$$

$$\overrightarrow{CP} \perp \overrightarrow{CB} \Rightarrow \overrightarrow{CP} \cdot \overrightarrow{CB} = 0 \quad (5)$$

$$\left[\left(\frac{9}{2} - \alpha\right)\mathbf{i} + \frac{3}{2}\mathbf{j}\right] \cdot [(9 - \alpha)\mathbf{i} + 3\mathbf{j}] = 0$$

$$\left(\frac{9}{2} - \alpha\right)(9 - \alpha) + \frac{9}{2} = 0 \quad (5)$$

$$2\alpha^2 - 27\alpha + 90 = 0$$

$$(2\alpha - 15)(\alpha - 6) = 0$$

$$\therefore \alpha = \frac{15}{2} \text{ or } \alpha = 6$$

$$|\overrightarrow{OC}| = |\alpha\mathbf{i}| = \alpha \quad (5)$$

$$\therefore |\overrightarrow{OC}| = 6$$

$$|\overrightarrow{OC}| = \frac{15}{2}$$

7. One end of a uniform rod of weight W and length $2a$ is attached to the end of a light string which hangs freely from a fixed point. A couple of moment G acts on the rod in a vertical plane containing the system. Find the tension in the string. Find the inclinations of the rod and the string when the system is in equilibrium. **Deduce that $G \leq Wa$**

$$\rightarrow T \cos \alpha = 0$$

$$T \neq 0 \rightarrow \cos \alpha = 0 \Rightarrow \alpha = \frac{\pi}{2} \quad (5)$$

$$\uparrow T \sin \alpha - W = 0$$

$$T = W \quad (5)$$

$$A \curvearrowright = 0$$

$$W \cdot a \cos \theta - G = 0$$

$$\cos \theta = \frac{G}{Wa} \leq 1 \quad (5)$$

$$G \leq Wa$$

$$\theta = \cos^{-1} \left(\frac{G}{Wa} \right) \quad (5)$$

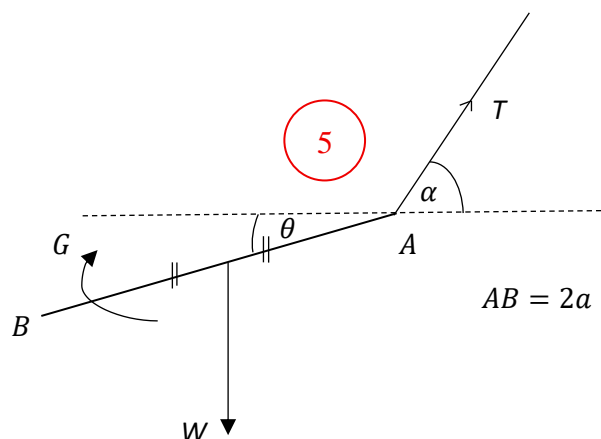

10 marks should be given to the figure if string is drawn vertically

8. A uniform rod AB of weight w and length $2a$ rests in equilibrium with A in contact with a rough plane inclined at α to the horizontal and B against a smooth vertical wall. The rod is perpendicular to the plane as shown in the diagram. If the coefficient of friction between the rod and rough plane is μ , then show that $\mu \geq \frac{\sin \alpha \cos \alpha}{2 - \sin^2 \alpha}$.

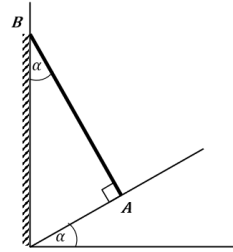

For the equilibrium of the system

$$B \curvearrowright Wa \sin \alpha - F \cdot 2a = 0 \quad (5)$$

$$F = \frac{W}{2} \sin \alpha$$

$$\uparrow R \cos \alpha + F \sin \alpha - W = 0 \quad (5)$$

$$R \cos \alpha = W - \frac{W}{2} \sin^2 \alpha$$

$$R = \frac{W}{2} \left(\frac{2 - \sin^2 \alpha}{\cos \alpha} \right) \quad (5)$$

$$\text{for equilibrium } \frac{F}{R} \leq \mu \quad (5)$$

$$\frac{\sin \alpha \cos \alpha}{2 - \sin^2 \alpha} \leq \mu$$

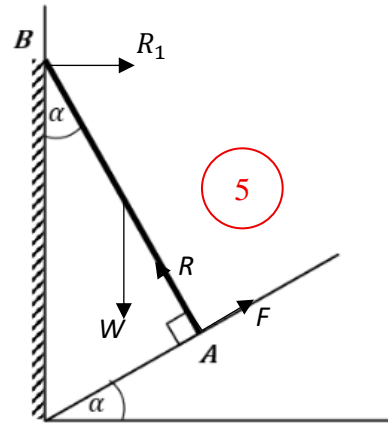

9. A bag contains 4 red balls and 6 blue balls which are equal in all respects, except for colour. Two balls are taken out at random without replacement.

(i) Find the probability that both balls are of the same colour.

(ii) Let Event A : "The first ball is red" and

Event B : "The second ball is red".

Are the events A and B independent? Give reasons.

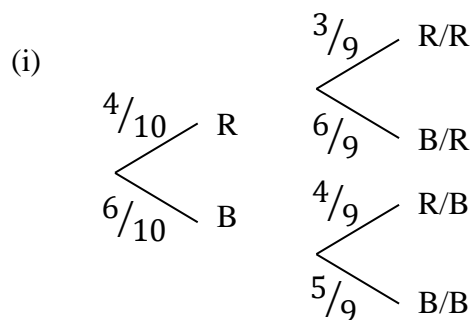

$$\text{Probability that both balls are in same colour} = \frac{4}{10} \times \frac{3}{9} + \frac{6}{10} \times \frac{5}{9} = \frac{42}{90} = \frac{7}{15} \quad (5)$$

(5)

Aliter Method

$$\begin{aligned} P(R \cap R) + P(B \cap B) &= P(R) \cdot P(R/R) + P(B) \cdot P(B/B) \\ &= \frac{4}{10} \times \frac{3}{9} + \frac{6}{10} \times \frac{5}{9} = \frac{42}{90} = \frac{7}{15} \end{aligned}$$

$$(ii) \quad P(A) = \frac{4}{10} = \frac{2}{5}$$

$$P(B) = \frac{4}{10} \cdot \frac{3}{9} + \frac{6}{10} \cdot \frac{4}{9} = \frac{36}{90} = \frac{2}{5}$$

$$P(A \cap B) = \frac{4}{10} \cdot \frac{3}{9} = \frac{12}{90} = \frac{2}{15} \quad (5)$$

$$P(A)P(B) = \frac{2}{5} \cdot \frac{2}{5} = \frac{4}{25} \quad (5)$$

$$P(A \cap B) \neq P(A)P(B). \therefore A \text{ and } B \text{ are not independent.} \quad (5)$$

10. The marks a , b , c , and d obtained by four students are in ascending order. Where a , b , c , and d are positive integers. The mean of the marks is 37. The mean of the top three marks is 39. The range of marks is 15. Find the mean of the least three marks. If the mean deviation of the distribution is 5, then find b and c .

$$a < b < c < d$$

$$\frac{a+b+c+d}{4} = 37 \Rightarrow a + b + c + d = 148 \rightarrow (1) \quad (5)$$

$$d - a = 15 \rightarrow (2)$$

$$\frac{b+c+d}{3} = 39 \Rightarrow b + c + d = 117 \rightarrow (3) \quad (5)$$

$$(1) - (2) \quad a = 148 - 117 = 31$$

$$(2) \Rightarrow d = 15 + 31 = 46$$

$$\therefore \frac{a+b+c}{3} = \frac{148-46}{3} = 34$$

$$b + c = 148 - (46 + 31) = 71$$

$$\therefore c = 71 - b$$

$$\text{mean deviation} = 5 = |31 - 37| + |b - 37| + |71 - b - 37| + |46 - 37| = 5 \times 4 = 20 \quad (5)$$

$$6 + 9 + |b - 37| + |b - 34| = 20$$

$$\therefore |b - 37| + |b - 34| = 5$$

$$\text{Since } b > 31, \text{ when } b = 32, |32 - 37| + |32 - 34| \neq 5$$

$$\text{Since } b > 31, \text{ when } b = 33, |33 - 37| + |33 - 34| = 5$$

$$b = 33$$

$$c = 38 \quad (5)$$

අධ්‍යාපන, උසස් අධ්‍යාපන සහ වෘත්තීය අධ්‍යාපන අමාත්‍යාංශය
கல்வி, உயர் கல்வி மற்றும் தொழிற கல்வி அமைச்சு
Ministry of Education, Higher Education and Vocational Education

G.C.E.(A.L) Support Seminar 2025

සංයුක්ත ගණිතය II
இணைந்த கணிதம் II
Combined Mathematics II

10 S II

* Answer five questions only.

Part B

(In this question paper, g denotes the acceleration due to gravity.)

11. (a) A car P starts from rest at point O when time $t = 0$ s and moves with a constant acceleration f m s⁻². It accelerates uniformly until $t = T$ s and then continues with the constant speed it gained. Another car Q starts from rest at the same point O at $t = (T + 2)$ s and moves with the same constant acceleration f m s⁻². Q maintains this acceleration for $\frac{3T}{2}$ s and then continues with the constant speed it gained. Both cars move in the same direction on a straight horizontal road.

Sketch velocity-time graphs for the motions of P and Q in the same diagram. **Hence,**

- (i) Find the distance between the cars P and Q in terms of f and T when their velocities are equal.
(ii) Show that Q **cannot** overtake P until Q gains its maximum speed.
(iii) Show that Q overtakes P at $t = \frac{17T+24}{4}$ s.

- (b) A river with two straight parallel banks flows with the constant velocity u . The points A , B and C are on the river banks such that $\angle ABC = \frac{\pi}{2}$.

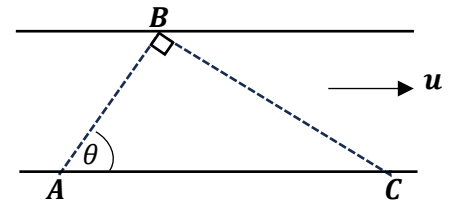

It is also given that $AC = a$ and $\angle BAC = \theta$; $(0 < \theta < \frac{\pi}{2})$

(see the adjoining figure)

A swimmer can swim with a constant speed $2u$ in still water, starts at A and swims along a straight line to reach B . Then he swims along a straight line to reach C . Assume that no time taken for turning.

By constructing the velocity triangle for the motion from A to B , or **otherwise,**

show that the magnitude of the velocity of swimmer along AB is $(\sqrt{3 + \cos^2\theta} + \cos\theta)u$.

Deduce the magnitude of velocity along BC .

Also show that the total time taken by the swimmer to reach C from A is

$$\frac{a}{3u} (\cos\theta\sqrt{3 + \cos^2\theta} + \sin\theta\sqrt{3 + \sin^2\theta} - 1)$$

Further, **deduce** the value of θ such that the two time periods along AB and BC are same.

11(a)

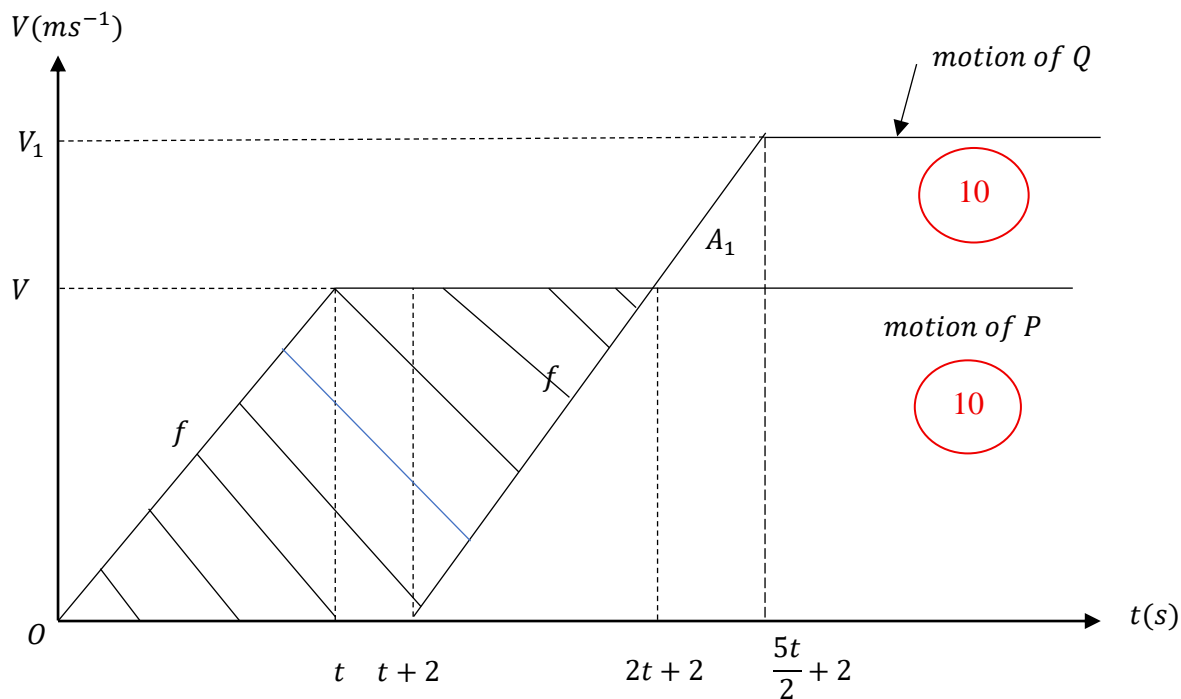

(i) when the velocities are equal

$$T = 2t + 2$$

 \therefore Distance travelled by (P - Q)

$$= \frac{1}{2} \times \text{shaded area}$$

$$= \frac{1}{2} \times (2ft + 2) \times V \quad (5)$$

$$\text{but } f = \frac{V}{t} \Rightarrow V = ft \quad (5)$$

$$\therefore \text{Distance} = \frac{2}{2}(t+2)ft = (t+2)ft \quad (5)$$

35

(ii). When Q reaches its maximum Distance between P and Q

$$= \text{Previous area} - A_1 \quad (5)$$

$$= (t+2)ft - \frac{1}{2} \times \frac{t}{2} \left(\frac{3ft}{2} - ft \right) \quad (5)$$

$$= (t+2)ft - \frac{ft^2}{8} \quad (5)$$

$$= \frac{ft}{8}(16 + 7t) \quad (5)$$

$$\text{this is always } > 0 \quad (5)$$

 \therefore Q cannot Overtakes P until it reaches its maximum speed. (5)

30

(iii). Let the time taken to Q to Over take P after $(2t + 2)s$ is to \therefore when Overtake P, 5

$$ft(t + 2) = \frac{1}{2} \times (t_0 + t_0 - \frac{t}{2}) \times \frac{ft}{2} \quad \text{5}$$

$$8(t + 2) = (4t_0 - t) \quad \text{5}$$

$$4t_0 = 9t + 16$$

$$t_0 = \left(\frac{9t + 16}{4}\right) s \quad \text{5}$$

25

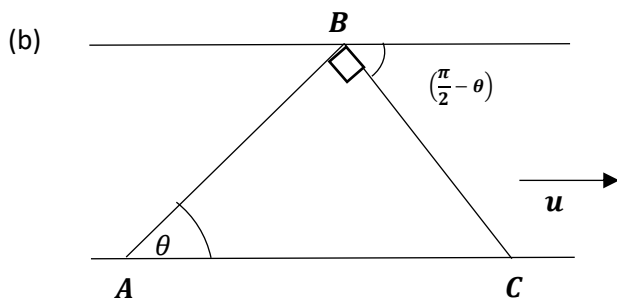

W – Water
E – Earth
S – swimmer

$$V_{(S,E)} = V_{(S,W)} + V_{(W,E)}$$

AB; = $2u + \vec{u}$ 5

BC; = $2u + \vec{u}$ 5

10

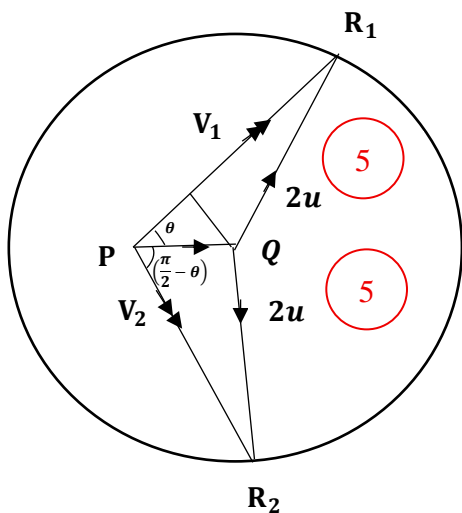

$PQR_1\Delta$; $V_{AB} = V_1$ 5

$$= u \cos \theta + \sqrt{(2u)^2 - (u \sin \theta)^2} \quad \text{5}$$

$$= u(\cos \theta + \sqrt{3 + \cos^2 \theta})$$

$$\begin{aligned}
 V_{BC} &= (V_{AB})_{\theta \rightarrow \left(\frac{\pi}{2} - \theta\right)} \quad (5) \\
 &= u \left(\cos \left(\frac{\pi}{2} - \theta \right) + \sqrt{3 + \cos^2 \left(\frac{\pi}{2} - \theta \right)} \right) = u \left(\sin \theta + \sqrt{3 + \sin^2 \theta} \right) \quad (5)
 \end{aligned}$$

25

$$\begin{aligned}
 t_{AC} &= t_{AB} + t_{BC} \\
 &= \frac{a \cos \theta}{V_1} + \frac{a \sin \theta}{V_2} \quad (5) \\
 &= \frac{a \cos \theta}{u(\cos \theta + \sqrt{3 + \cos^2 \theta})} + \frac{a \sin \theta}{u(\sin \theta + \sqrt{3 + \sin^2 \theta})} \quad (5) \\
 &= \frac{a}{u} \left[\frac{\cos(\sqrt{3 + \cos^2 \theta}) - \cos \theta}{3} + \frac{\sin \sqrt{3 + \sin^2 \theta} - \sin \theta}{3} \right] \quad (5) \\
 &= \frac{a}{3u} \left(\cos \theta \cdot \sqrt{3 + \cos^2 \theta} + \sin \left(\sqrt{3 + \sin^2 \theta} - 1 \right) \right)
 \end{aligned}$$

$$\begin{aligned}
 t_{AB} &= t_{BC} \\
 \frac{a \cos \theta}{u(\cos \theta + \sqrt{3 + \cos^2 \theta})} &= \frac{a \sin \theta}{u(\sin \theta + \sqrt{3 + \sin^2 \theta})} \quad (5)
 \end{aligned}$$

when $\theta = \frac{\pi}{4}$; L.H.S = R.H.S

$$\therefore \theta = \frac{\pi}{4} \quad (5)$$

25

12. (a) The figure shows a vertical cross section passing through the centers of mass of two uniform wedges X and Y and three particles P, Q and R . A wedge Y of mass M is placed on the **rough** horizontal face of the fixed wedge X . α and β are the inclinations of the smooth inclined planes of X and Y respectively. A and B are two small smooth pulleys fixed to the wedges X and Y respectively. C is a fixed pulley in the same vertical plane such that BC is horizontal. Two particles P and Q of masses m_1 and m_2 are attached to the ends of a light inextensible string passing over the pulleys B and C . Another light inextensible string passing over the pulley A connected to Y to the particle R of mass m_3 which is on the inclined face of X . The coefficient of friction between X and Y is μ . The system is released from rest with the strings taut. Assuming that during the entire motion of the particle P , is in contact with the inclined plane of Y , write equations sufficient to determine the accelerations of the particles and the wedges.

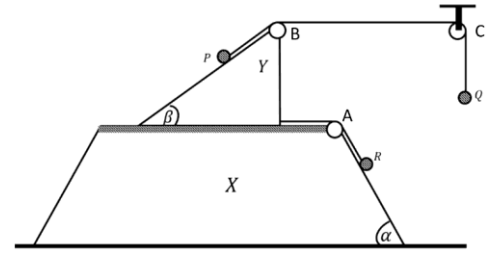

(b) One end of a light inextensible string of length $2a$ is attached to a fixed-point O , and the other end to a Particle P_1 of mass m . The particle is held at A which is same level of O , such that $OP_1 = 2a$ and projected vertically downwards with speed $\sqrt{5ag}$. Show that the speed V of the Particle P_1 when OP_1 makes an angle θ ($0 < \theta < \frac{\pi}{2}$) with horizontal is given by $V^2 = ag(5 + 4 \sin \theta)$ and find the tension in the string. When P_1 reaches its lowest point B , it collides directly in the horizontal direction with a particle P_2 of mass m which has been projected vertically upwards with a speed $\sqrt{2ag}$ from a point at a depth of $3a$ below O . In the motions of P_1, P_2 after the collision, P_1 continues circular motion and comes to a momentary rest at point D , which is the angle OD is β with horizontal. The particle P_2 moves under gravity and reaches E which is the point vertically below D .

(i) If the coefficient of restitution between P_1 and P_2 is $e = \frac{1}{3}$, show that the velocity of P_1 after collide is \sqrt{ag} .

(ii) Show that $\beta = \sin^{-1}\left(\frac{3}{4}\right)$, Also show that the particle reaches E when $t = \sqrt{\frac{7a}{16g}}$ sec, after impact.

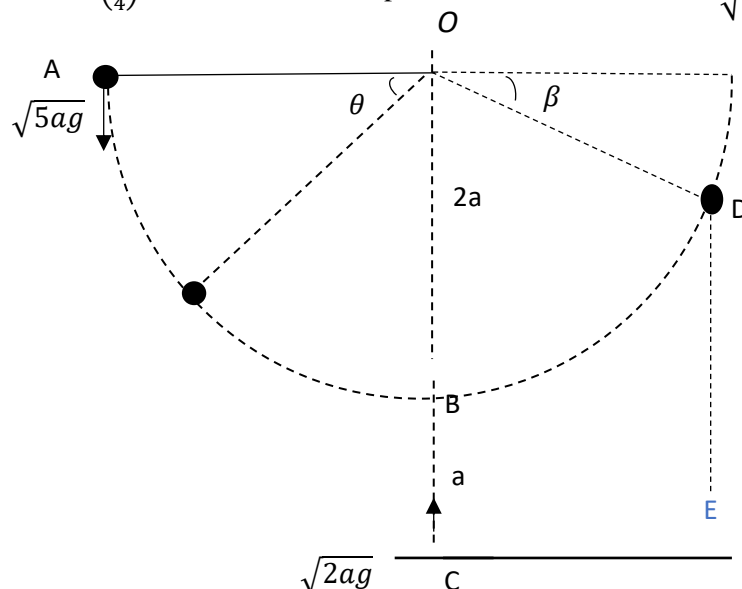

(a)

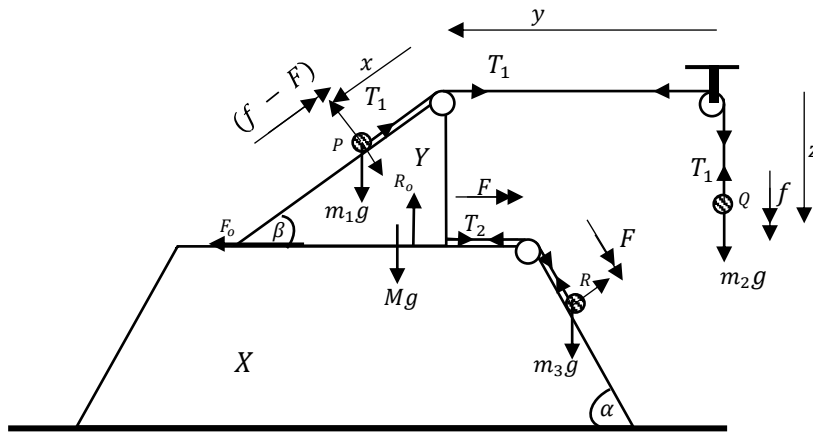

$$\begin{aligned} x + y + z &= l \\ \dot{x} + \dot{y} + \dot{z} &= 0 \\ \ddot{x} &= -(\ddot{y} + \ddot{z}) \end{aligned}$$

5

$$a_{(Y,E)} = F \rightarrow$$

$$a_{(P,Y)} = (f - F) \nearrow_{\beta}$$

$$a_{(Q,E)} = f \downarrow$$

$$a_{(R,E)} = F \searrow_{\alpha} \quad 5$$

$$a_{(P,E)} = \begin{matrix} (f - F) \nearrow_{\beta} \\ F \rightarrow \end{matrix} \quad 5$$

$F = ma$

For Q, \downarrow $m_2g - T_1 = m_2f \quad 10$

For P, \nearrow_{β} $T_1 - m_1g \sin\beta = m_1(f - F + F \cos\beta) \quad 10$

For R, \searrow_{α} $m_3g \sin\alpha - T_2 = m_3(F) \quad 10$

For the system (Y and P),

\rightarrow $T_1 + T_2 - F_0 = MF + m_1((f - F)\cos\beta + F) \quad 15$

\uparrow $R_0 - Mg - m_1g = m_1(f - F)\sin\beta \quad 10$

For Y, $F_0 = \mu R_0 \quad 5$

75

(b). By the conservation of energy, we have

$$(T.E)_A = (T.E)_B$$

$$\frac{1}{2}m \cdot 5ag + 0 = \frac{1}{2}mV^2 - mg \cdot 2a \sin \theta \quad (10)$$

$$5ag = V^2 - 4agsin \theta$$

$$V^2 = ag(5 + 4sin \theta) \quad (5)$$

15

For particle P_1 : apply $F = Ma$

$$T - mg \sin \theta = m \frac{V^2}{2a}$$

$$T = mg \sin \theta + m \frac{ag(5 + 4sin \theta)}{2a} \quad (10)$$

$$T = \frac{mg}{2} (6sin \theta + 5) \quad (5)$$

When $\theta = \frac{\pi}{2}$ velocity of P_1

$$V^2 = ag \left(5 + 4sin \frac{\pi}{2} \right)$$

$$= 9ag$$

$$V = 3\sqrt{ag} \quad (5)$$

Velocity of P_2 $V^2 = U^2 + 2ga$

$$V = 0$$

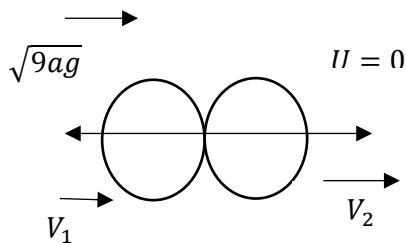

$$V_2 - V_1 = \frac{1}{3} \cdot 3\sqrt{ag} \quad (5)$$

$$V_1 + V_2 = 3\sqrt{ag} \quad (5)$$

$$V_1 = \sqrt{ag} \quad (5)$$

35

After impact By the conservation of energy, we have

$$(T.E)_B = (T.E)_D$$

$$\frac{1}{2}m \cdot ag + mg(-2a) = 0 - mg \cdot h \quad (10)$$

$$h = \frac{3a}{2} \quad (5)$$

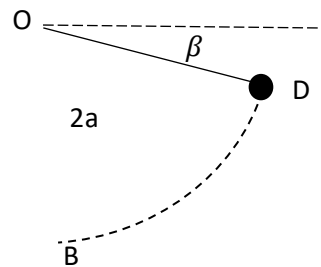
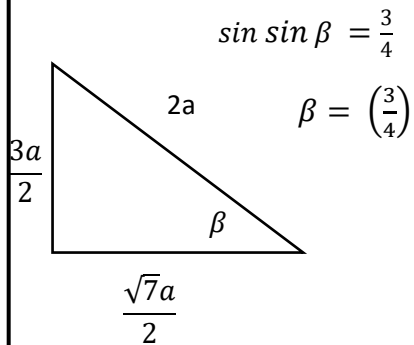

For particle P_1 from BE \rightarrow

$$s = ut + \frac{1}{2}gt^2$$

$$2a \cos \cos \beta = V_2 t$$

$$t = \frac{2a \cos \cos \beta}{V_2} \quad (10)$$

$$t = \frac{2 \cdot a \cdot \frac{\sqrt{7}a}{2}}{2\sqrt{ag}}$$

$$t = \sqrt{\frac{7a}{16g}} \quad (25)$$

13. A particle Q of mass m is suspended by a light elastic string of natural length $2l$ and modulus of elasticity λ from a fixed point A , which is at height $5l$ vertically above another fixed point B . When Q is in equilibrium, the length of the string is $3l$. Show that $\lambda = 2mg$. A particle P of mass m is attached to the end of another light elastic string of natural length l_0 and modulus of elasticity $2mg$, the other end is attached to B . P is projected vertically upwards with a speed $\sqrt{6gl}$. If P just reaches Q , by applying principle of conservation of energy, show that $l_0 = l$. Find the velocity of P when $BP = l$.

When the length of the string BP is $(l + x)$, show that the equation of motion of P is given by $\ddot{x} + \frac{2g}{l} \left(x + \frac{l}{2}\right) = 0$. Let $x + \frac{l}{2} = X$, show that $\ddot{X} + \omega^2 X = 0$ where ω is a real constant to be determined. Find the centre and amplitude of the simple harmonic motion of P . When the particle P reaches Q , it sticks with Q . When the composite particle S is at a height $(l + y)$ above B , show that the equation of motion of S is $\ddot{y} + \left(\frac{3g}{2l}\right)y = 0$.

Find the centre and amplitude of the simple harmonic motion of S . Also Show that the total time taken for the lower string to become slack for the first time from the time that P was projected is

$$\sqrt{\frac{l}{6g}} \left(\pi + 6 - 2\sqrt{6} + \sqrt{3} \cos^{-1} \left(\frac{1}{3} \right) \right)$$

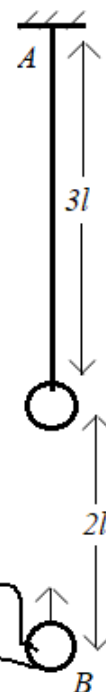

For Q

$$\uparrow T_E - mg = 0 \quad (5)$$

$$\frac{\lambda l}{2l} = mg$$

$$\lambda = 2mg \quad (5)$$

10

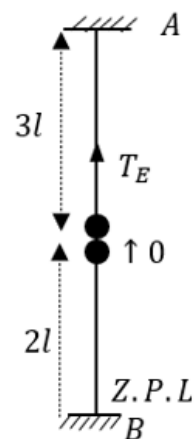

For (P) , from B to reach (Q)

P.C.E

$$0 + \frac{2mg}{2l_0} (2l - l_0)^2 + mg \cdot 2l = \frac{1}{2} m \cdot 6gl \quad (20)$$

$$(2l - l_0)^2 = ll_0$$

$$l_0^2 - 5ll_0 + 4l^2 = 0$$

$$(l_0 - 4l)(l_0 - l) = 0 \quad (5)$$

$$0 < l_0 < 2l \Rightarrow l_0 = l \quad (5)$$

For (Q)

$$\uparrow v^2 = u^2 + 2as$$

$$v_0^2 = 6gl - 2gl$$

$$v_0 = 2\sqrt{gl} \quad (5)$$

35

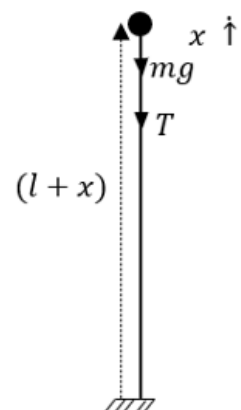

Applyin $F = ma$ for (P) \uparrow

$$-T - mg = m\ddot{x}$$

5

$$5 \quad -\frac{2mgx}{l} - mg = m\ddot{x}$$

$$\ddot{x} + \frac{2g}{l}\left(x + \frac{l}{2}\right) = 0$$

$$x + \frac{l}{2} = X$$

Differentiate w.r.t. t

$$\dot{x} = \dot{X}$$

5

$$\ddot{x} = \ddot{X}$$

$$\ddot{X} + \omega^2 X = 0 \Rightarrow \omega = \sqrt{\frac{2g}{l}}$$

5

\therefore SHM

Centre; $\ddot{x} = 0$

$$x = 0$$

$$x = -\frac{l}{2}$$

centre is at a height $\frac{l}{2}$ above B

5

$\dot{x} = 0$ at a height $2l$ above B

$$\therefore \text{amplitude} = 2l - \frac{l}{2}$$

$$= \frac{3l}{2}$$

5

30

Applying $F = ma$ For (S) \uparrow

$$T_A - T_B - 2mg = 2m\ddot{y} \quad (10)$$

$$\frac{2mg}{2l}(4l - y - 2l) - \frac{2mgy}{l} - 2mg = 2m\ddot{y}$$

$$g - \frac{gy}{2l} - \frac{gy}{l} - g = \ddot{y}$$

$$\ddot{y} + \frac{3g}{2l}y = 0 \quad (5)$$

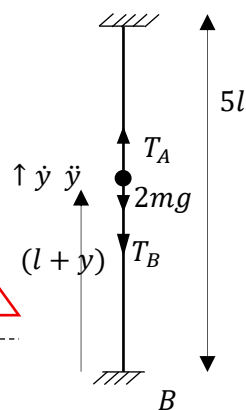

$$\therefore SHM \Rightarrow \omega_1 = \sqrt{\frac{3g}{2l}} \quad (5)$$

centre ; $\dot{y} = 0 \Rightarrow y = 0$

(5) centre is at a height l above B

amplitude = $2l - l = l$ (5)

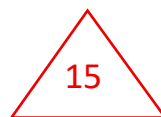

$$\cos \theta = \frac{l/2}{3l/2} = \frac{1}{3}$$

$$\theta = \cos^{-1}\left(\frac{1}{3}\right) \quad (5)$$

For (P) $\uparrow v = u + at$

$$2\sqrt{gl} = \sqrt{6gl} - gt_0 \quad (5)$$

$$t_0 = (\sqrt{6} - 2)\sqrt{\frac{l}{g}}$$

$$t = \frac{\theta}{\omega} + \frac{\pi}{2\omega_1} + (\sqrt{6} - 2)\sqrt{\frac{l}{g}}$$

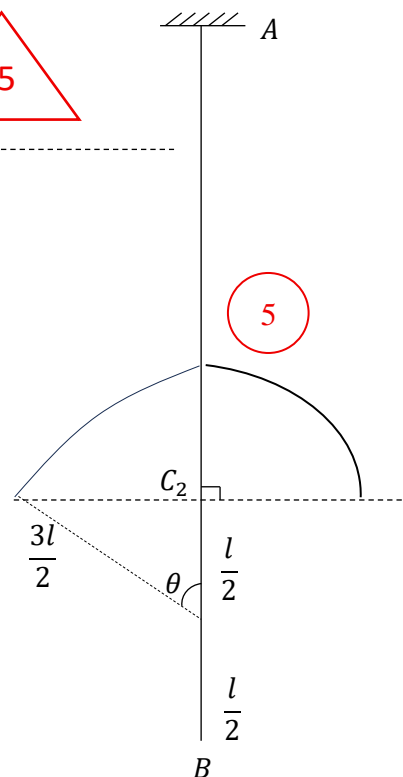

$$= \sqrt{\frac{l}{6g}} \cos^{-1}\left(\frac{1}{3}\right) + \frac{\pi}{2} \sqrt{\frac{2l}{3g}} + (\sqrt{6} - 2)\sqrt{\frac{l}{g}} \quad (5)$$

$$= \sqrt{\frac{l}{6g}} \left(\sqrt{3} \cos^{-1}\left(\frac{1}{3}\right) + \pi + 6 - 2\sqrt{6} \right)$$

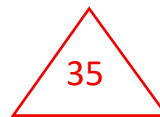

14. (a) A, B, C and D are four distinct points on the oxy -plane. Position vectors of A and B are $\mathbf{i} + 3\mathbf{j}$ and $3\mathbf{i} + 9\mathbf{j}$ respectively, in usual notation. Also $\overrightarrow{BC} = 2\mathbf{i} - 3\mathbf{j}$ and $\overrightarrow{BD} = 6\mathbf{i} - 9\mathbf{j}$. Show that the points O, A and B are collinear. The lines OC and AD meet at E . For a positive constant α , $OE : OC = \alpha : 1$. Show that $\mathbf{e} = 5\alpha\mathbf{i} + 6\alpha\mathbf{j}$ where \mathbf{e} is the position vector of the point E with respect to the vector origin. For another positive constant β , $AE : AD = \beta : 1$. Obtain another expression for \mathbf{e} in terms of β .

Hence, show that $\alpha = \frac{3}{7}$ and $\beta = \frac{1}{7}$. Further, show that $\widehat{OBD} = \cos^{-1} \left(\frac{7}{\sqrt{130}} \right)$.

(b) $ABCDEF$ is a regular hexagon of side a and O is the centre. Forces of magnitudes 2, 3, 4, 5 units act along AB, BC, CD, DE respectively and a variable force F acts at G in the plane of the hexagon. Cartesian axes OX, OY are chosen parallel to AB, BD respectively. The resultant of the system of forces will be denoted by R .

- If $F = 0$ show that $|R| = 7$ and find the Cartesian equation of the line of action of R .
- Find the magnitude and direction of F , indicating the direction clearly in a figure. If the line of action of R is to coincide with OD , find $|R|$.
- If F is chosen to make the system of forces reduce to a couple, show that the moment of the couple is of magnitude $\frac{21\sqrt{3}a}{2}$. Now, if the force acting on AB is removed, deduce the resultant of the new system of forces.

$$(a) \quad \overrightarrow{OA} = \mathbf{i} + 3\mathbf{j}, \overrightarrow{OB} = 3\mathbf{i} + 9\mathbf{j}, \overrightarrow{BC} = 2\mathbf{i} - 3\mathbf{j}, \overrightarrow{BD} = 6\mathbf{i} - 9\mathbf{j}$$

$$\overrightarrow{OB} = 3(\mathbf{i} + 3\mathbf{j}) = 3\overrightarrow{OA} \Rightarrow O, A, B \text{ are collinear. } \quad (5)$$

$$OE : OC = \alpha : 1$$

$$\overrightarrow{OE} = \alpha \overrightarrow{OC} \quad (5)$$

$$= \alpha(\overrightarrow{OB} + \overrightarrow{BC})$$

$$= \alpha(3\mathbf{i} + 9\mathbf{j} + 2\mathbf{i} - 3\mathbf{j})$$

$$= 5\alpha\mathbf{i} + 6\alpha\mathbf{j} \quad \rightarrow (1) \quad (5)$$

$$AD = \beta : 1$$

$$\overrightarrow{OE} = \overrightarrow{OA} + \overrightarrow{AE} \quad (5)$$

$$= \overrightarrow{OA} + \beta \overrightarrow{AD} \quad (5)$$

$$= \mathbf{i} + 3\mathbf{j} + \beta(\overrightarrow{AB} + \overrightarrow{BD})$$

$$= \mathbf{i} + 3\mathbf{j} + \beta(2\mathbf{i} + 6\mathbf{j} + 6\mathbf{i} - 9\mathbf{j}) \quad (5)$$

$$= \mathbf{i} + 3\mathbf{j} + \beta(8\mathbf{i} - 3\mathbf{j})$$

$$= (8\beta + 1)\mathbf{i} + (3 - 3\beta)\mathbf{j} \quad \rightarrow (2) \quad (5)$$

$$(1) = (2)$$

$$8\beta + 1 = 5\alpha \quad (5)$$

$$3 - 3\beta = 6\alpha$$

$$\frac{8\beta + 1}{3 - 3\beta} = \frac{5}{6}$$

$$48\beta + 6 = 15 - 15\beta$$

$$\beta = \frac{9}{63} = \frac{1}{7} \quad (5)$$

$$\therefore 3 - \frac{3}{7} = 6\alpha = \frac{18}{7}$$

$$\therefore \alpha = \frac{3}{7} \quad (5)$$

Let $\widehat{OBD} = \theta$

$$\vec{BO} = -3\mathbf{i} - 9\mathbf{j}$$

$$\vec{BD} = 6\mathbf{i} - 9\mathbf{j}$$

$$\vec{BO} \cdot \vec{BD} = |\vec{BO}| |\vec{BD}| \cos \theta$$

$$(-3\mathbf{i} - 9\mathbf{j}) \cdot (6\mathbf{i} - 9\mathbf{j}) = \sqrt{3^2 + 9^2} \sqrt{6^2 + 9^2} \cos \theta$$

$$\frac{-18 + 81}{\sqrt{3 \cdot 30} \sqrt{3 \cdot 39}} = \cos \theta = \frac{63}{3\sqrt{3 \cdot 10} \sqrt{3 \cdot 13}} = \frac{7}{\sqrt{130}}$$

$$\theta = \cos^{-1}\left(\frac{7}{\sqrt{130}}\right)$$

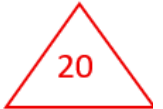

(b)

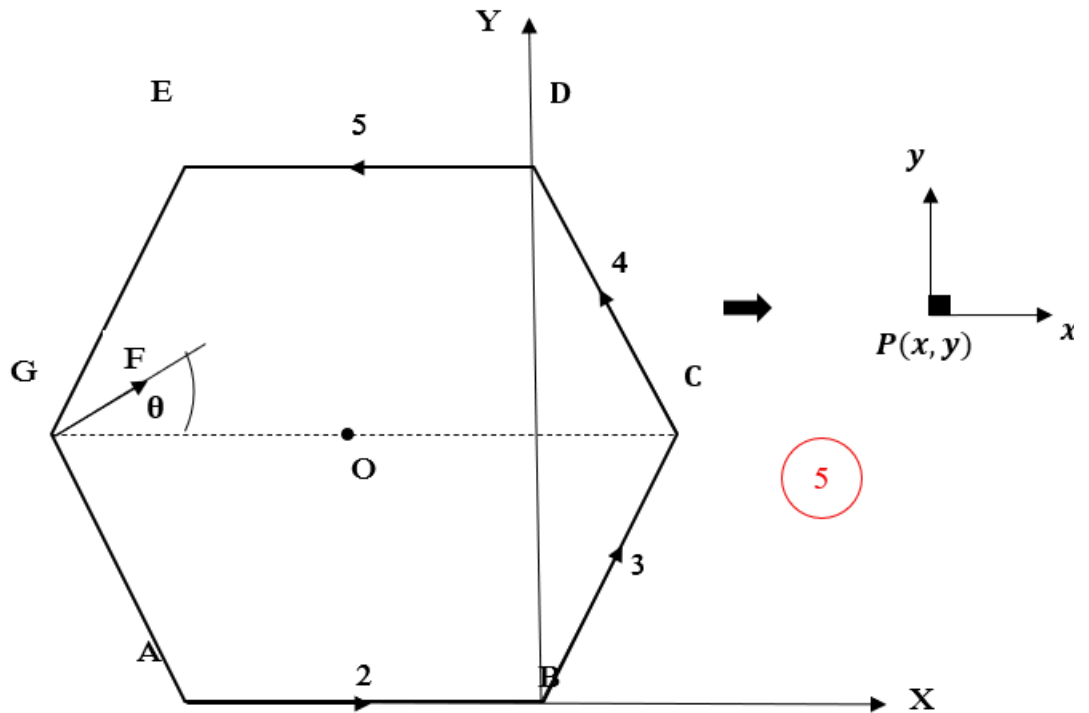

i) If $\underline{F} = \underline{O}$

$$\rightarrow X = 2 + 3 \cos 60^\circ - 4 \cos 60^\circ - 5$$

$$= -3 - \cos 60^\circ$$

$$= -\frac{7}{2}$$

$$\uparrow Y = 3 \cos 30^\circ + 4 \cos 30^\circ$$

$$= 7 \cos 30^\circ$$

$$= \frac{7\sqrt{3}}{2}$$

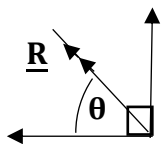

$$R^2 = (7/2)^2 + (7\sqrt{3}/2)^2 = 7^2$$

$$R = 7 \Rightarrow |R| = 7$$

5

$$\vec{B} \searrow \text{Res} = \vec{B} \searrow \text{Sys}$$

$$Y \cdot x - X \cdot y = 5 \cdot 2a \cos 30^\circ + 4 \cdot a \cos 30^\circ$$

$$\frac{7\sqrt{3}}{2}x + \frac{7}{2}y = 14a \frac{\sqrt{3}}{2}$$

$$y + \sqrt{3}x = 2\sqrt{3}a$$

5

25

$$(ii) \rightarrow X = F \cos \theta - 7/2 > 0$$

$$\uparrow Y = F \sin \theta + 7\sqrt{3}/2 > 0$$

$$\frac{Y}{X} = \tan 60^\circ \Rightarrow Y = \sqrt{3}X$$

5

$$F \sin \theta + 7\sqrt{3}/2 = \sqrt{3}(F \cos \theta - 7/2) \quad (1)$$

since **R** goes through **O**,

$$\vec{O} \searrow \text{Sys} = 0$$

$$(2 + 3 + 4 + 5)a \cos 30^\circ - F \sin \theta \cdot a = 0$$

$$F \sin \theta = 14\sqrt{3}/2$$

$$F \sin \theta = 7\sqrt{3}$$

5

$$\textcircled{1} \Rightarrow 7\sqrt{3} + 7\sqrt{3}/2 = \sqrt{3}(F \cos \theta - 7/2)$$

$$2\sqrt{3} = F \cos \theta - 7/2$$

$$F \cos \theta = 14$$

5

$$\frac{F \sin \theta}{F \cos \theta} = \frac{7\sqrt{3}}{14} \Rightarrow \tan \theta = \sqrt{3}/2$$

$$\theta = \tan^{-1} \sqrt{3}/2$$

5

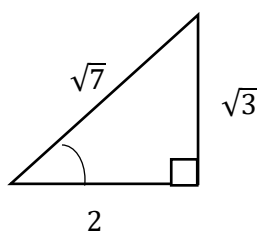

$$F \sin \theta = 7\sqrt{3}$$

$$F \cdot \frac{\sqrt{3}}{\sqrt{7}} = 7\sqrt{7} \text{ units.}$$

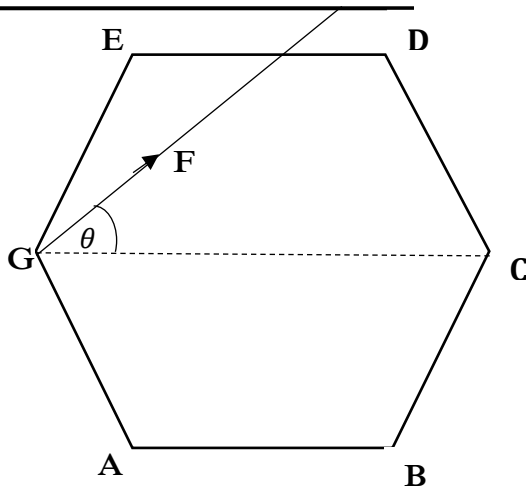

5

25

$$(iii) \quad \rightarrow F \cos \theta - 7/2 = 0 \Rightarrow F \cos \theta = 7/2 \quad \text{--- (2) (5)}$$

$$\uparrow F \sin \theta + 7\sqrt{3}/2 = 0 \Rightarrow F \sin \theta = -7\sqrt{3}/2 \quad \text{--- (3) (5)}$$

$$\textcircled{2}, \textcircled{3} \Rightarrow \tan \theta = -\sqrt{3} \Rightarrow \theta = -60^\circ$$

$$\textcircled{2} \Rightarrow F \cos(-60^\circ) = 7/2$$

$$F = 7 \quad \text{(5)}$$

F is 7 units along GA ↗

Moment of the Couple

$$= 0 \text{ Sys}$$

$$= (2 + 3 + 4 + 5 + 7)a \cos 30^\circ$$

$$= \frac{21\sqrt{3}a}{2} \quad \text{(5)}$$

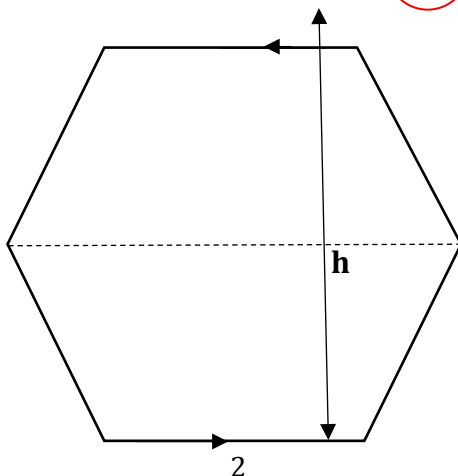

$$2h = 21 \frac{\sqrt{3}}{2} a$$

$$h = 21 \frac{\sqrt{3}}{4} a$$

∴ If the force acting along AB is removed resultant of the new system is of magnitude 2 Units to the direction of BA at a height of $\frac{21\sqrt{3}a}{4}$ from AB (x-axis). (5)

25

15. (a) Three uniform rods AB, CD and AD , each of equal length $2a$ and equal weight w , and another uniform rod BC of weight λw and of length $2a$, are jointed smoothly at their ends. The framework is suspended from a fixed point by a light inextensible string OA . A light rod jointed to the midpoints of AB and BC to maintain the framework in the shape of a square. It is kept in equilibrium with AC vertical, as shown in the adjoining figure, by applying a horizontal force of magnitude w at B .

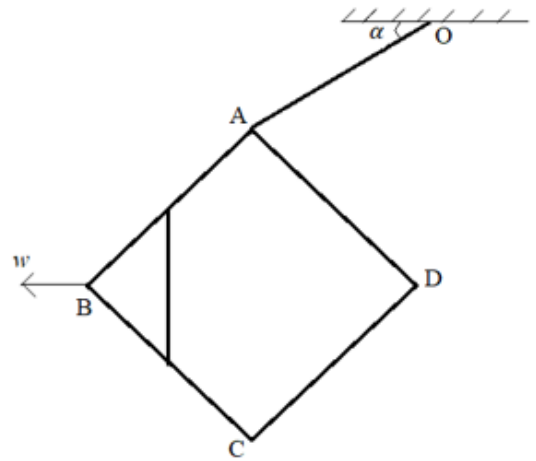

- (i) Show that the horizontal and vertical components of the reaction at C on the rod BC are $\frac{w}{2}$ and w respectively.
- (ii) Show that $\lambda = 3$
- (iii) Calculate the stress in the light rod.

(b) Five light rods freely jointed to form a framework in which $2AB = BC = BD = DC$, and $B\hat{A}D = 90^\circ$. The framework is smoothly hinged to a fixed point at A and kept in equilibrium in a vertical plane. A weight w is suspended from B and a force P is applied at C , perpendicular to BC in the same plane of the frame as shown in the figure.

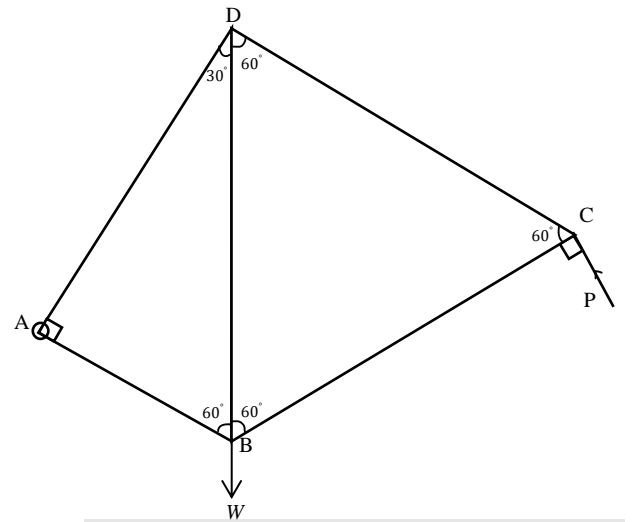

Show that $P = \frac{\sqrt{3}}{5}w$.

Draw the stress diagram using Bow's notation and find the stresses in each rods, stating whether they are tensions or thrusts.

(a) (i) for AD and CD

$$A \cup X_1 4a \cos 45^\circ - 2W a \cos 45^\circ = 0 \quad (10)$$

$$X_1 = \frac{W}{2} \quad (5)$$

For CD

$$D \cup Y_1 \cdot 2a \cos 45^\circ - X_1 2a \sin 45^\circ - W a \cos 45^\circ = 0 \quad (10)$$

$$2Y_1 = W + W$$

$$Y_1 = W \quad (5)$$

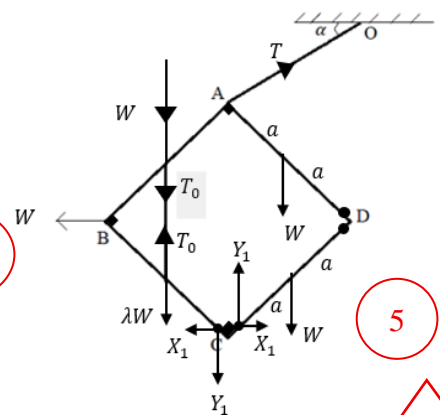

5
35

(ii) For AB and BC

$$A \cup W(1 + \lambda)a \cos 45^\circ - X_1 4a \sin 45^\circ - W2a \cos 45^\circ = 0$$

$$W(1 + \lambda) = 2W + 2W$$

$$1 + \lambda = 4 \Rightarrow \lambda = 3$$

10

15

(iii) For BC, B $\cup T_0 a \cos 45^\circ - 3W a \cos 45^\circ - \frac{W}{2} 2a \sin 45^\circ - W2a \sin 45^\circ = 0$

$$T_0 = 6W$$

10

5

15

(b) A $\cup P \cdot \frac{5a}{2} - Wa \sin 60^\circ = 0$

$$P = \frac{\sqrt{3}W}{5}$$

Rod	Stress	Magnitude
AB	Tension	$W/5$
BC	Tension	$W/5$
CD	Thrust	$2W/5$
AD	Thrust	$2\sqrt{3}W/5$
BD	Tension	$4W/5$

10

10

10

10

10

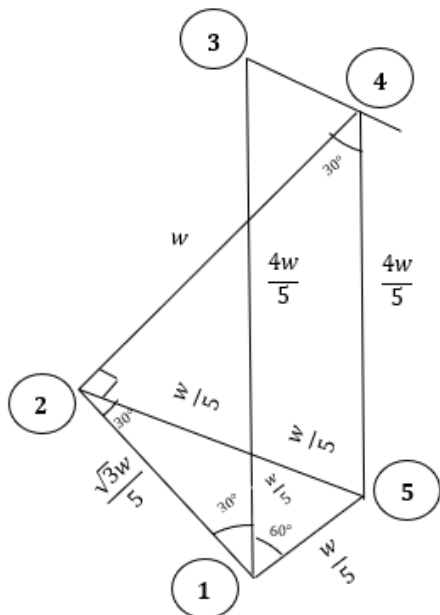

25

85

16. (a) Show that the centre of mass of

- (i) A thin uniform hemispherical shell of radius a is at a distance $\frac{a}{2}$ from its centre.
- (ii) A uniform right circular cone of height h is at a distance $\frac{h}{3}$ from the centre of the base of the cone.

(b) An Olympic lamp is made by rigidly fixing a hemispherical shell on the top of a uniform frustum of a hollow right circular cone of radii $\frac{a}{2}$ and a and of height $\frac{\sqrt{3}a}{2}$. The frustum rigidly stands on the top surface of a uniform solid cylinder as shown in the adjoining figure as follows.

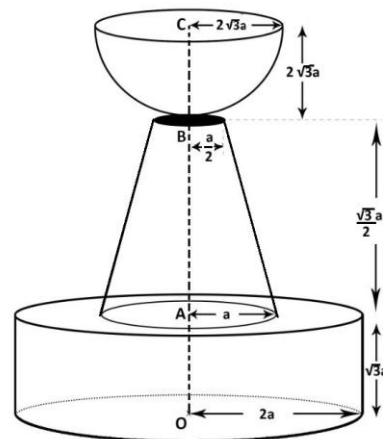

- Uniform hemispherical shell is of radius $2\sqrt{3}a$ and centre C .
- Solid cylinder is of radius $2a$ and height $\sqrt{3}a$.
- The mass per unit volume of the solid cylinder is $\frac{2\sigma}{\pi}$, and the mass per unit area of the frustum and hemispherical shell is $\frac{a\sigma}{\pi}$
- Assume that the total mass of the Olympic lamp does not change due to the welding.
- The top B of the frustum is closed with a **light** circular disk of the same radius.

Show that the distance from O to the centre of mass of the Olympic lamp is $\left(\frac{24\sqrt{3}+371}{48+51\sqrt{3}}\right)a$.

Consider $\left(\frac{24\sqrt{3}+371}{48+51\sqrt{3}}\right)a \approx 3a$.

The Olympic lamp stands on a rough inclined plane. Assuming that the contact is rough enough to prevent from slipping find the inclination of the plane when the Olympic lamp is about to topple.

(a) (i) By symmetry the centre of mass G lies on the x -axis

$$\Delta m = 2\pi(a \sin \theta) a \rho \theta, \text{ where } \sigma \text{ is the mass per unit area} \quad (5)$$

Let $OG = \bar{x}$

$$\bar{x} = \frac{\int_0^{\frac{\pi}{2}} 2\pi(a \sin \theta) a \sigma a \cos \theta d\theta}{\int_0^{\frac{\pi}{2}} 2\pi(a \sin \theta) a \sigma d\theta} \quad (5) + (5)$$

$$= \frac{[a \sin \theta]_0^{\frac{\pi}{2}}}{[-\cos \theta]_0^{\frac{\pi}{2}}} \quad (5) + (5)$$

$$= \frac{a}{2} \quad (5)$$

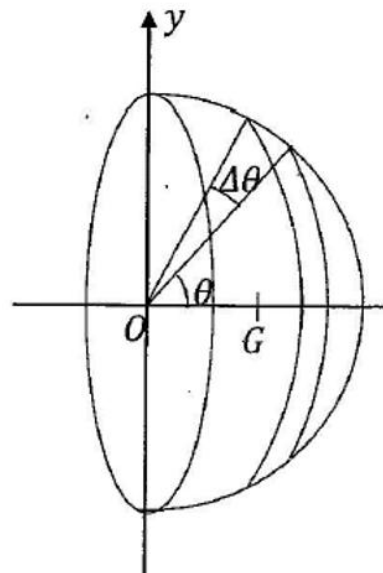

(ii) By symmetry the centre of mass G lies on the x -axis

$$h = l \cos \theta \quad (5)$$

$\Delta m = 2\pi(x \sin \theta) \Delta x \sigma$, where σ is the mass per unit length

$$\bar{x} = \frac{\int_0^l x \cos \theta 2\pi \sigma x \sin \theta dx}{\int_0^l 2\pi \sigma x \sin \theta dx} \quad (5) + (5)$$

$$= \frac{\cos \theta \int_0^l x^2 dx}{\int_0^l x dx}$$

$$= \frac{\left[\frac{h x^2}{2} \right]_0^l}{\left[\frac{x^2}{2} \right]_0^l} \quad (5)$$

$$= \frac{2h}{3} \quad (5)$$

\therefore The required distance $= \frac{h}{3}$

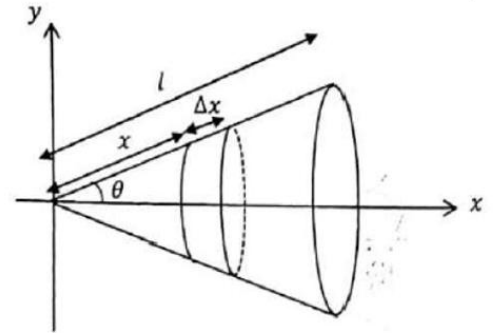



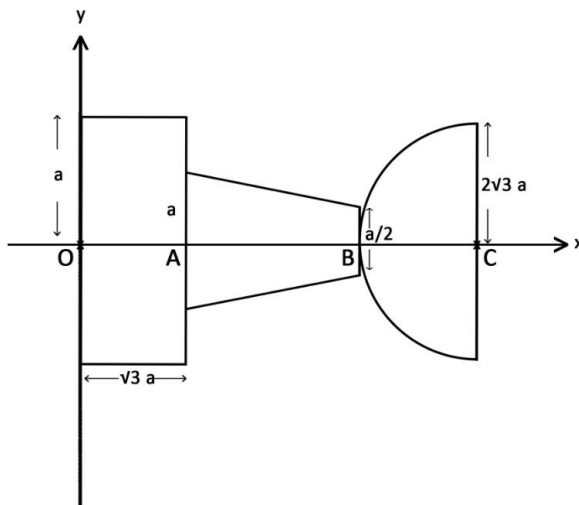

25

(b)

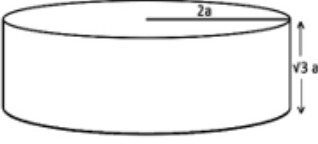

According to the symmetry C.O.G lies on the X axis. 5

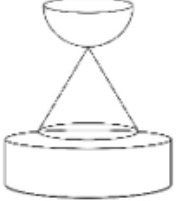
OBJECT	MASS	DISTANCE FROM O to C.O.G
	$8\sqrt{3}a^3\sigma$ 5	$\frac{\sqrt{3}a}{2}$ 5
	$2a^3\sigma$ 5	$(\frac{a}{\sqrt{3}} + \sqrt{3}a) = \frac{4a}{\sqrt{3}}$ 5
	$\frac{a^3\sigma}{2}$ 5	$\sqrt{3}a + \frac{\sqrt{3}}{2}a + \frac{a}{2\sqrt{3}} = \frac{5a}{\sqrt{3}}$ 5
	$24a^3\sigma$ 5	$\frac{5\sqrt{3}a}{2}$ 5
	$(\frac{16\sqrt{3}+51}{2})a^3\sigma$ 5	\bar{X}

let $a^3\sigma = \lambda$

Taking

moments around Y axis

$$\left(\frac{16\sqrt{3}+51}{2}\right)\lambda\bar{X} = 8\sqrt{3} \times \frac{\sqrt{3}a}{2}\lambda + 2 \times \frac{4a}{\sqrt{3}}\lambda - \frac{\lambda}{2} \cdot \frac{5a}{\sqrt{3}} + 24\lambda \frac{5\sqrt{3}}{2}a \quad 10$$

$$\left(\frac{16\sqrt{3}+51}{2}\right)\bar{X} = 12a + \frac{8a}{\sqrt{3}} - \frac{5a}{2\sqrt{3}} + 60\sqrt{3}a$$

$$\left(\frac{16\sqrt{3}+51}{2}\right)\bar{X} = \frac{(24\sqrt{3}+371)a}{2\sqrt{3}} \quad 5$$

$$\bar{X} = \frac{(24\sqrt{3}+371)}{16\sqrt{3}+51} \cdot \frac{a}{\sqrt{3}}$$

$$\bar{X} = \frac{(24\sqrt{3}+371)}{48+51\sqrt{3}} \approx 3.02a$$

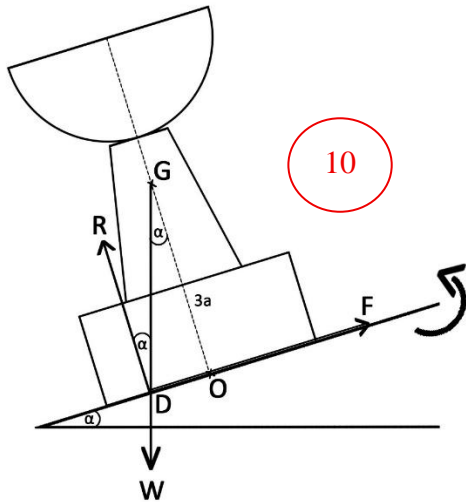

10

ODG△

$$\tan \alpha = \frac{OD}{3a}$$

$$OD = 3a \tan \alpha$$

Olympic lamp is about to topple

$$OD < 2a$$

$$3a \tan \alpha < 2a$$

$$\tan \alpha < \frac{2}{3}$$

$$\alpha < \tan^{-1}\left(\frac{2}{3}\right)$$

10

When Olympic lamp is about to topple

$$OD = 2a$$

$$3a \tan \alpha = 2a$$

$$\tan \alpha = \frac{2}{3}$$

$$\alpha = \tan^{-1}\left(\frac{2}{3}\right)$$

10

17. (a) A box contains 4 red balls and 6 blue balls which are equal in all respects, except for colour. Two balls are taken out twice at random from the box, one after the other.

The experiment is conducted as follows:

- A fair die is rolled, and if the die shows an even number, the balls are taken out with replacement.
- If the die shows an odd number, the balls are taken out without replacement.

- (i) Find the probability that both balls drawn are **red**.
- (ii) If it is observed that both balls taken out are red, find the probability that the selection was made **without replacement**.

- (b) Consider the following frequency distribution with k class intervals, where x_i is the class mark and f_i is the frequency of the i^{th} class interval, respectively for $i = 1, 2, 3 \dots k$

Midpoint of the class interval	Frequency
x_1	f_1
x_2	f_2
.....
x_i	f_i
.....
x_k	f_k

Write down the mean and the standard deviation of the above frequency distribution.

The deposits of 100 customers of a micro savings and loan community club over five years are listed below in the table.

Deposit in 10,000 rupees	Number of members
15 – 19	10
20 – 24	20
25 – 29	f
30 – 34	g
35 – 39	p
40 – 44	7
Total	100

It is given that frequency of the modal class is 28, the frequency of the median class is 21 and $\text{Median} < \text{Mode} < 34.5$, find f , g and p , justifying your answers.

- (i) Calculate the median deposit of a member in rupees.
- (ii) Using an assumed mean of 320,000 rupees, calculate the mean deposit of a member in rupees.
- (iii) Show that the standard deviation of the deposits, correct to one decimal place, is 69,500 rupees.
- (iv) Find the number of members who have deposited less than 395,000 rupees.

- (a) (i). A – Event of both balls drawn being red
 E – Event of the die showing an even number
 O – Event of the die showing an odd number

$$P(E) = P(O) = \frac{1}{2} \quad (5)$$

$$P(A/E) = \frac{4}{10} \times \frac{4}{10} \quad (10)$$

$$P(A/O) = \frac{4}{10} \times \frac{3}{9} \quad (10)$$

$$\begin{aligned} P(A) &= P(E) \times P(A/E) + P(O) \times P(A/O) \\ &= \frac{1}{2} \times \frac{4}{10} \times \frac{4}{10} + \frac{1}{2} \times \frac{4}{10} \times \frac{3}{9} \\ &= \frac{2}{25} + \frac{1}{15} = \frac{11}{75} \quad (5) \end{aligned}$$

40

Alternate

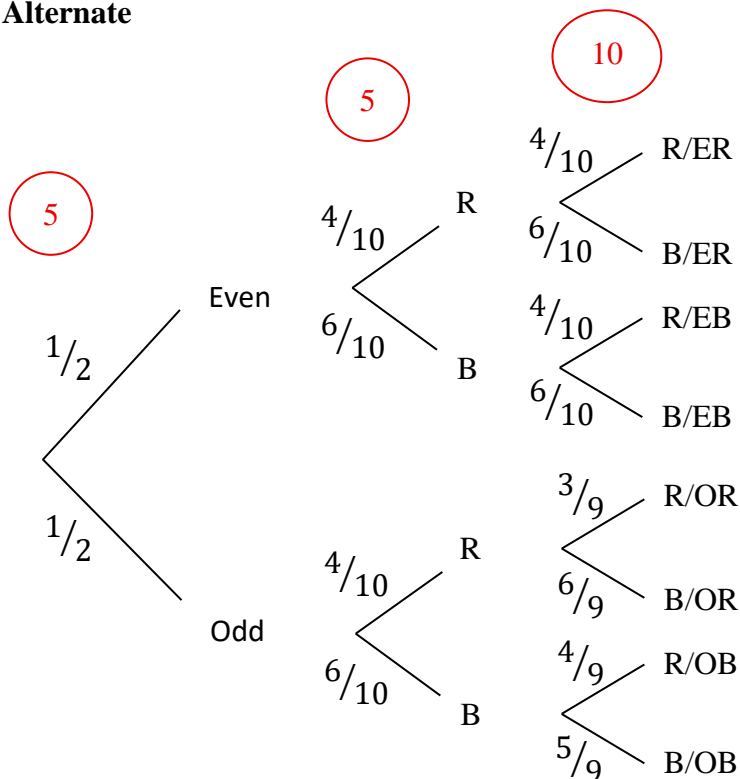

$$\begin{aligned} \text{Probability that both balls are red} &= \frac{1}{2} \times \frac{4}{10} \times \frac{4}{10} + \frac{1}{2} \times \frac{4}{10} \times \frac{3}{9} \\ &= \frac{2}{25} + \frac{1}{15} = \frac{11}{75} \end{aligned}$$

For the equation

(ii) Using Bayes' Theorem;

$$\begin{aligned} P(O/R) &= \frac{P(O) \cdot P(R/O)}{P(R)} \\ &= \frac{1}{2} \cdot \frac{4}{10} \cdot \frac{3}{9} = \frac{1}{15} \times \frac{75}{11} \\ &= \frac{5}{11} \end{aligned}$$

20

(b).

class mark	frequency	$f_i x_i$	$f_i x_i^2$
x_1	f_1	$f_1 x_1$	$f_1 x_1^2$
x_2	f_2	$f_2 x_2$	$f_2 x_2^2$
...
x_i	f_i	$f_i x_i$	$f_i x_i^2$
...
x_t	f_k	$f_k x_k$	$f_k x_k^2$
	$\sum_{i=1}^n f_i$	$\sum_{i=1}^n f_i x_i$	$\sum_{i=1}^n f_i x_i^2$

$$\text{Mean } \bar{x} = \frac{\sum_{i=1}^n f_i x_i}{\sum_{i=1}^n f_i}$$

$$\text{standard deviation } = \sigma = \sqrt{\frac{\sum_{i=1}^n f_i x_i^2}{n} - \bar{x}^2}$$

10

Class boundaries 10,000	Class mark x_i	Frequency f_i	Cumulative frequency F_i	u_i	$f_i u_i$	U_i^2	$f_i U_i^2$
14.5-19.5	17	10	10	-3	-30	9	90
19.5-24.5	22	20	30	-2	-40	4	80
24.5-29.5	27	21	51	-1	-21	1	21
29.5-34.5	32	28	79	0	0	0	0
34.5-39.5	37	14	93	1	14	1	14
39.5-44.5	42	7	100	2	14	4	28
		100			-63		233

Let $u_i = \frac{x_i - A}{C}$ where A is the assumed mean and C is the class width.

Median class = class in which the $\left(\frac{100}{2}\right)^{\text{th}}$ observation included = 24.5-29.5

$$\therefore f = 28 \rightarrow (1)$$

$$\text{modal class} = 29.5 - 34.5$$

$$\text{since median} < \text{Mode} < 34.5$$

$$\therefore g = 28 \rightarrow (2)$$

$$\therefore p = 100 - (10 + 30 + 7 + 28 + 21)$$

$$\therefore p = 14$$

$$(i). \text{ median Deposit} = \left(24.5 + \frac{5}{21} \times 20\right) \times 10,000$$

$$\text{median deposit} = (29.26) \times 10,000$$

$$= 293,000 \text{ rupees}$$

$$(ii). \text{ Mean} = \left[32 + 5 \times \left(\frac{-63}{100}\right)\right] \times 10,000$$

$$= 288,500$$

$$(iii). \text{ standard deviation} = \sqrt{25 \left[\left(\frac{233}{100}\right) - \left(\frac{63}{100}\right)^2 \right]}$$

$$= \sqrt{48.3275} = 6.95$$

$$= 6.95 \times 10,000$$

$$= \text{Rs } 69,500$$

$$(iv). 93$$

80